



# VERTO

**VERTO** to marka szybko zyskująca uznanie i dobrą opinię wśród nabywców. Ceniona przez majsterkowiczów za swoją jakość w oferowanej cenie.

**VERTO** to...

- elektronarzędzia i akcesoria skierowane do majsterkowiczów, przystosowane do prac przy średnich obciążeniach

**VERTO** is a brand that quickly earns recognition and good opinion among buyers. It is valued by DIY enthusiasts for its quality at offered price.

**VERTO** is...

- power tools and accessories oriented at DIY enthusiasts, fitted for operation at moderate loads

**VERTO** – это марка, быстро завоевывающая признание среди покупателей. Высоко ценится мастерами-любителями, благодаря выгодному соотношению цены и качества.

**VERTO** это...

- электроинструмент и принадлежности для мастеров-любителей, предназначенные для среднего уровня нагрузки и интенсивности работ







acesoria do elektronarzędzi / accessories for power tools / Zubehöriteile für Elektrowerkzeuge / принадлежности к электроинструментам / принадлежності до електроінструменту / elektromos szerszám tartozékok / accesoriiile pentru sculele electrice / príslušenství pro elektrické nářadí / príslušenstvo k elektrickým náradiam / pribor za električna orodja / elektriniili įrankių priedai / elektroinstrumentu aksesuarii / elektritööriistade tarvikud / аксесоари за електроинструменти / pribor za električne alate / pribor za elektroređaje / εξαρτήματα ηλεκτρικών εργαλείων / accesorios para herramienta eléctrica / accessori per elettrotrattenti / acessórios para eletro-ferramentas / accessoires pour mini perceuse

**HM** z nakładką węglastą / with solid carbide insert / mit Widia-Aufsatz / с вуглецевою напайкою / з карбідною напайкою / vidialetétes / cu eclisă de Widia / s vidiovou destičkou / s vidiovou doštičkou / z vidia prevleka / padengta karbidu (vidia) / ar dakšveida uzliku / viltkattega / с наставкою от метало-керамични сплава / s nastavkom od vidija / sa vidija naglavkom / με πλακίδια καρβιδίου Βολφράμιου / con capa de vidia / con la snoda in vidia / con bico de vidia / avec embouts vidia

 rzepek / hook and loop / klettverschluss / пулючка / пулючка / tépőzár / scai / suchý zip / velcro / varnāleša / atplēšams savienojums / takjakinnittus / велкро / Ойкак / rep / Вёлкро / velcro / lappola / velcro / velcro

 do szlifierek stolowych / for bench grinders / für Tischnschleifmaschinen / для настольных шлифовальных машин / до верстатки шлифовальной / asztali kőszűrőhöz / pentru polizoare de banc / pro stolní brusky / k stolným brúskam / za mizne brusilnike / stacionariems šlifvokliams / galds slīpmašīnām / lihpinkidele / za nastolnu šlifauforose / za stolne brusilice / za stone brusilice / για λεωντήρες πδγκου / para amoladoras de banco / Per levigatrici da banco / para plainas de mesa / Pour meuleuses d'établi

 do szlifierek katowych / for angle grinders / für Winkelschleifer / для угловых шлифовальных машин / до шліфмашинки кутової (бонгарок) / sarokcsiszológépek / pentru polizoare unghiulare / pro úhlové brusky / k úhlovým brúskam / za kotne brusilnike / kamprianiems šlifvokliams / lenka slīpmašīnām / nurklīvjāiele / за ѱ-ε-η-ουαυήφοσε / za kutne brusilice / za ugaone brusilice / για γωνιακός λεωντήρες / para amoladoras angulares / per lucidatrici angolari / para rebarbadoras de ángulo / pour meuleuses d'angle

 do wiertarek / for drills / für Bohrmaschinen / для дрелел / до дрелел / füróréphez / pentru borosăine / pro vrtáčky / k vrtáčkám / za vrtnalike / grežtāvams / urtmašīnām / trellidete / за пробителни машини / za bušilice / za bušilice / για дрάνανα / para taladros / per trapani / para berbequins / pour perceuses

 do drewna / for wood / für Holz / для дрелесины / no dreray / fāhoz / pentru lemn / do dřeva / na drevo / za les / medienai / kokam / puidule / за дрелесина / za drvo / za drvo / για ξύλο / para madera / per legno / para madeira / Forêts de bois

 do betonu / for concrete / für Beton / для бетона / no betonij / betonhoz / pentru beton / do betonu / na betón / za beton / betonui / betonam / betoonile / za бемон / za beton / za beton / για μετόν / para hormigón / per calcestruzzo / para betão / Forêts pour béton

 do metalu / for metal / für Metall / для металла / no metaly / fémhez / pentru metal / do kovu / na kov / za kovino / metalui / metālam / metallile / za meman / za metal / za metal / για μέταλλο / para metal / per metallo / para metal / Forêts à métal

 do płyty wiórowej / for chipboards / für Spanholzplatte / для ДСП / no ДСП / pozdrjatelemhez / pentru placă din aşchii de lemn / pro třískovou desku / na pilinovi desku / za iverko / presuotų pjūvenų plėkštem / skaidu plātēm / puittasplaadile / за малашумоу плочасту / za ivericu / za ivericu / για μορισανίδες / para placa de fibra / per pannello truciolare / para charpa de madeira aglomerada / pour panneau de copeaux de bois

 końcówka „quatro” / Quatro tip / „quatro”-Endstück / наконечник „quatro” / наконечник „quatro” / „quatro”-betét / capăt „quatro” / koncovka „quatro” / koncovka „quatro” / nastavek „quatro” / antgalis „quatro” / „quatro”-uzgalis / quatro-otsak / накрайник „quatro” / nastavak „quatro” / nastavak „quatro” / μύτη quatro / punta „quatro” / estremità „quattro” / ponta quatro / embout „quatro”

 két wierzchołkowy / point angle / Eckenwinkel / угол при вершине / вертикальный нут / csúcsszög / unghi de vârf / vrcholový úhel / vrcholový uhol / sovřšni kut / viršūnis kampas / smalles lenkjs / vertikaalne nurk / ѱ-ε-η-ουαυήφοσε / kut vrha / ugaoni vřh / γωνία κορυφής / ángulo vertical / ángulo di vertice / ángulo de ponta / angle de sommet

**S4 TYPE** typ trzpienia wiertła / drill shank type / Typ des Bohrerstiftes / тип стержня сверла / тип хвостовика сверла / fürórszár-típus / tipul țijeii burghiuului / typ trnu vrtáku / typ trña vrtáka / tip stebła svedra / gražto koto tipas / urbja pamatnes tips / puuri varre tüüp / тип на цыма на сарелнопо / tip klina svrdla / tip vretena burgije / τύπος στέλεχος τριπανοίου / tipo de vástago de la broca / tipo di mandrino portaripunta per trapano / tipo do bico de broca / type de tige de foret

## WKREŃAK

Screwdriver / Schraubendreher / Отвертка / Відкритка / Csavarbehajtó / Šurubelnitā / Šroubovák / Skrutkovač AKU + príslušenstvo / Izvijač / Akumulatorinis gręžtuvas - suktuvas / Skręvgriezis / Krivikeeraja / Omeprnka / Akumulatorski odvijač / Akumulatorski odvrtac / Καταβίδι / Destomillador / Cacciavite / Chave de fenda / Tournevis / Schroeendraaier

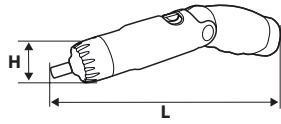

Ref.	L [mm]	H [mm]	[kg]		EAN
50G016	275	55	0,3	0/12	5902062500168

## WKREŃAK AKUMULATOROWY

Cordless screwdriver / Akku-Schrauber / Отвертка аккумуляторная / Шрубоверт аккумуляторный / Akkus csavarbehajtó / Šurubelnitā jāra fir / Akumulátorový šroubovák / Skrutkovač AKU / Baterijski izvijač / Akumulatorinis suktuvas / Skręvgriezis akumulatore / Akukrivikeeraja / Omeprnka / Akumulatorski odvijač / Akumulatorski odvrtac / Επαναφορτιζόμενο καταβίδι / Destomillador a batería / Cacciavite senza filo / Chave de fenda de bateria / Tournevis à batteries / Accu schroeendraaier

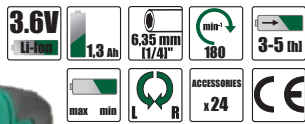
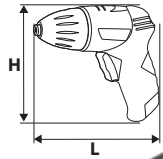

Ref.	L [mm]	H [mm]	[kg]		EAN
50G137	170	135	0,37	0/10	5902062501370

## WKREŃAK AKUMULATOROWY

Cordless screwdriver / Akku-Schrauber / Отвертка аккумуляторная / Шрубоверт аккумуляторный / Akkus csavarbehajtó / Šurubelnitā jāra fir / Akumulátorový šroubovák / Skrutkovač AKU / Baterijski izvijač / Akumulatorinis suktuvas / Skręvgriezis akumulatore / Akukrivikeeraja / Omeprnka / Akumulatorski odvijač / Akumulatorski odvrtac / Επαναφορτιζόμενο καταβίδι / Destomillador a batería / Cacciavite senza filo / Chave de fenda de bateria / Tournevis à batteries / Accu schroeendraaier

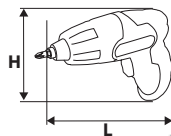

Ref.	L [mm]	H [mm]	[kg]		EAN
50G138	150	145	0,38	0/12	5902062501387

## WIERTARKO-WKREŃARKA AKUMULATOROWA

Cordless drill / Akku-Bohrschrauber / Дрель-шуруповерт аккумуляторный / Дрель-шубоверт аккумуляторный / Akkus fúró csavarozó / Perforator jāra fir / Akumulátorová vrtačka-šroubovák / Vřtačka AKU / Baterijski izvijač/vrtalnik / Akumulatorinis gręžtuvas - suktuvas / Akumulatore urbjmašina-skręvgriezis / Akudrell / Бормашина / Akumulatorska bušilica / Akumulatorska busilica / Επαναφορτιζόμενο βρανανοκατάβίδο / Taladradora atomilladora a batería / Trapano avvitavite senza filo / Aparafuradora de bateria / Perceuse-visseuse à batterie / Accu boor-draaimachine

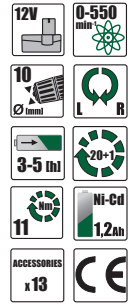
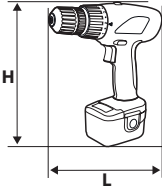

Ref.	L [mm]	H [mm]	[kg]		EAN
50G172	220	245	1,35	0/6	5902062501721

## WIERTARKO-WKREŃARKA AKUMULATOROWA

Cordless drill / Akku-Bohrschrauber / Дрель-шуруповерт аккумуляторный / Дрель-шубоверт аккумуляторный / Akkus fúró csavarozó / Perforator jāra fir / Akumulátorová vrtačka-šroubovák / Vřtačka AKU / Baterijski izvijač/vrtalnik / Akumulatorinis gręžtuvas - suktuvas / Akumulatore urbjmašina-skręvgriezis / Akudrell / Бормашина / Akumulatorska bušilica / Akumulatorska busilica / Επαναφορτιζόμενο βρανανοκατάβίδο / Taladradora atomilladora a batería / Trapano avvitavite senza filo / Aparafuradora de bateria / Perceuse-visseuse à batterie / Accu boor-draaimachine

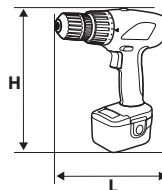

Ref.	L [mm]	H [mm]	[kg]		EAN
50G174	220	245	1,42	0/6	5902062501745

## WIERTARKO-WKREŃARKA AKUMULATOROWA

Cordless drill / Akku-Bohrschrauber / Дрель-шуруповерт аккумуляторный / Дрель-шубоверт аккумуляторный / Akkus fúró csavarozó / Perforator jāra fir / Akumulátorová vrtačka-šroubovák / Vřtačka AKU / Baterijski izvijač/vrtalnik / Akumulatorinis gręžtuvas - suktuvas / Akumulatore urbjmašina-skręvgriezis / Akudrell / Бормашина / Akumulatorska bušilica / Akumulatorska busilica / Επαναφορτιζόμενο βρανανοκατάβίδο / Taladradora atomilladora a batería / Trapano avvitavite senza filo / Aparafuradora de bateria / Perceuse-visseuse à batterie / Accu boor-draaimachine

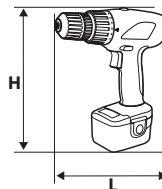

Ref.	L [mm]	H [mm]	[kg]		EAN
50G175	220	245	1,42	0/6	5902062501752

# VERTO

## WIERTARKO-WKRĘTARKA AKUMULATOROWA

Cordless drill / Akku-Bohrschrauber / Дрель-шуруповерт аккумуляторный / Дриль-шурупверт аккумуляторный / Akkus fűró csavarozó / Perforator fără fir / Akumulátorová vrtačka-šroubovák / Vrtačka AKU / Baterijski izvijač/vrtalnik / Akumulatorinis gręžuvas - suktuvus / Akumulatora urbjamašina-skrūvgręzius / Akudrell / Бормашина / Akumulatorska bušilica / Akumulatorska busilica / Επαναφορτιζόμενο βραπανοκατάρτιδο / Taladradora atomilladora a batería / Trapano avvitavite senza filo / Aparafuradora de bateria / Perceuse-visseuse à batterie / Accu boor-draaimachine

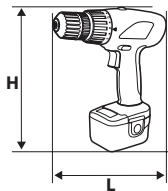

Ref.	L [mm]	H [mm]	[kg]	⊠	EAN
50G178	220	245	1,53	0/6	5902062501783

## WIERTARKO-WKRĘTARKA AKUMULATOROWA

Cordless drill / Akku-Bohrschrauber / Дрель-шуруповерт аккумуляторный / Дриль-шурупверт аккумуляторный / Akkus fűró csavarozó / Perforator fără fir / Akumulátorová vrtačka-šroubovák / Vrtačka AKU / Baterijski izvijač/vrtalnik / Akumulatorinis gręžuvas - suktuvus / Akumulatora urbjamašina-skrūvgręzius / Akudrell / Бормашина / Akumulatorska bušilica / Akumulatorska busilica / Επαναφορτιζόμενο βραπανοκατάρτιδο / Taladradora atomilladora a batería / Trapano avvitavite senza filo / Aparafuradora de bateria / Perceuse-visseuse à batterie / Accu boor-draaimachine

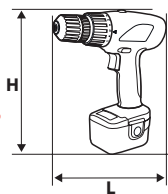

Ref.	L [mm]	H [mm]	[kg]	⊠	EAN
50G177	220	245	1,53	0/6	5902062501776

## AKUMULATOR

Battery / Akkumulator / Аккумулятор / Аккумулятор / Akkumulátor / Acumulator / Akumulátor / Akumulator / Akumulatorius / Akumulators / Aku / Аккумулятор / Akumulator / Akumulator / Ηλεκτρικός συσσωρευτής / Batería / Batteria / Batterie / Accu



Ref.	V	do modelu	⊠	EAN
50G172-12	12	50G172	0/1	5902062469212
50G174-12	14,4	50G174; 50G175	0/1	5902062469212
50G175-12	14,4	50G175	0/1	5902062180865
50G177-12	18	50G177	0/1	5902062180858
50G178-12	18	50G178; 50G177	0/1	5902062469236

## MINISZLIFIERKA

Minigrinder / Minischleifmaschine / Минишлифмашина / Мiнишлифмашина / Multifunciós fűrgép / Minipolizor / Minibruska / Bruska mini + príslušenstvo / Mini brusilnik / Mini šljifoklis / Šljfmašina mini / Minijahvati teleskoopalus / Шляф мини / Brusilica mini / Brusilica mini / Mini - τροχειο / Mini atoladora recta / Minitrapano fresatore / Esmerilhadora mini / Mini-ponceuse / Mini slijpmachine

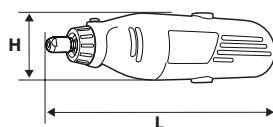

Ref.	L [mm]	H [mm]	[kg]	⊠	EAN
51G014	213	55	0,65	0/10	5902062510143

## STOJAK TELESKOPOWY DO MINISZLIFIERKI

Telescopic stand for minigrinder / Teleskopgestell für Minischleifer / Стойка телескопическая для прямой шлифмашины / Штатив телескопичний до мінішлифмашинки / Teleszkópos tartó mini csiszológéphez / Stativ telescopic pentru mini polizor / Teleskopický stojánek do minibrusky / Teleskopický stojan na minibrúsku / Teleskopsko stojalo za minibrusilnik / Teleskopinis stovas mini šljifokliui / Teleskopisks statnis mini-slijpmašīnai / Minilijvija teleskoopoidik / Телескопична подпора за мини шлайфмашина / Teleskopski stalak za mini-brusilicu / Teleskopski stalak za minibrusilicu / Τηλεσκοπικός ορθοστάτης για μικρό τροχειο / Soporte telescópico para atoladora recta / Supporto telescopic per minitrapano fresatore / Suporte telescópico p. Mini Disco de limar / Bâti telescopicque à mini-meuleuse / Telescopische steun voor minischuurmachine



Ref.	L [mm]	[kg]	⊠	EAN
51G002	800	0,44	0/4	5902062510020

## GIĘTKI WAŁEK DO MINISZLIFIERKI

Flexible shaft for minigrinder / Flex. Walze / Вал гибкий / Валик гнучкий для мінішлифмашинки / Flexibilis szár / Osie flexibilă p/U minimaşină de şlefuit / Ohebný váleček / Náhon ohybný pre mini brúsku / Gibko držalo / Lankstus velenas / Lokanais pagarinātājs mini slijpmašīnai / Paindiv vars minilijvija jaoks / Удължител гъвкав / Crijevo za mini brusilicu / Crevo za mini brusilicu / Ρολλό από εύκαμπτο υλικό / Manguera flexible / Rullo flessibile / Rolo flexivel / Arbre flexible / Flexibele as



Ref.	L [mm]	[kg]	⊠	EAN
51G003	1000	0,36	0/4	5902062510037

## WIERTARKA UDAROWA

Impact drill / Bohrhämmer / Дрель ударная / Дрель ударный / Útvefúró / Perforator de lovit / Přiklepová vrtačka / Přiklepová vrtačka / Udarni vrtnik / Grežtuvas su kalimu / Sitiēna urbjašina / Löökdrell / Бормашина ударна / Udarna bušilica / Udarna busilica / Κρουστικό δράπανο / Taladro de impacto / Trapano a percussione / Berbequim de impacto / Perceuse à choc / Slagboormachine



Ref.	L [mm]	H [mm]	[kg]	⊞	EAN
50G505	278	210	1,84	0/10	5902062505057

## WIERTARKA UDAROWA

Impact drill / Bohrhämmer / Дрель ударная / Дрель ударный / Útvefúró / Perforator de lovit / Přiklepová vrtačka / Přiklepová vrtačka / Udarni vrtnik / Grežtuvas su kalimu / Sitiēna urbjašina / Löökdrell / Бормашина ударна / Udarna bušilica / Udarna busilica / Κρουστικό δράπανο / Taladro de impacto / Trapano a percussione / Berbequim de impacto / Perceuse à choc / Slagboormachine



Ref.	L [mm]	H [mm]	[kg]	⊞	EAN
50G509	278	210	1,9	0/10	5902062505095

## WIERTARKA UDAROWA

Impact drill / Bohrhämmer / Дрель ударная / Дрель ударный / Útvefúró / Perforator de lovit / Přiklepová vrtačka / Přiklepová vrtačka / Udarni vrtnik / Grežtuvas su kalimu / Sitiēna urbjašina / Löökdrell / Бормашина ударна / Udarna bušilica / Udarna busilica / Κρουστικό δράπανο / Taladro de impacto / Trapano a percussione / Berbequim de impacto / Perceuse à choc / Slagboormachine



Ref.	L [mm]	H [mm]	[kg]	⊞	EAN
50G517	310	200	2,1	0/10	5902062505071

## WIERTARKA UDAROWA

Impact drill / Bohrhämmer / Дрель ударная / Дрель ударный / Útvefúró / Perforator de lovit / Přiklepová vrtačka / Přiklepová vrtačka / Udarni vrtnik / Grežtuvas su kalimu / Sitiēna urbjašina / Löökdrell / Бормашина ударна / Udarna bušilica / Udarna busilica / Κρουστικό δράπανο / Taladro de impacto / Trapano a percussione / Berbequim de impacto / Perceuse à choc / Slagboormachine



Ref.	L [mm]	H [mm]	[kg]	⊞	EAN
50G518	320	200	2,0	0/10	5902062505088

## WIERTARKA UDAROWA

Impact drill / Bohrhämmer / Дрель ударная / Дрель ударный / Útvefúró / Perforator de lovit / Přiklepová vrtačka / Přiklepová vrtačka / Udarni vrtnik / Grežtuvas su kalimu / Sitiēna urbjašina / Löökdrell / Бормашина ударна / Udarna bušilica / Udarna busilica / Κρουστικό δράπανο / Taladro de impacto / Trapano a percussione / Berbequim de impacto / Perceuse à choc / Slagboormachine



Ref.	L [mm]	H [mm]	[kg]	⊞	EAN
50G512	300	225	2,2	0/10	5902062505125

## WIERTARKA UDAROWA

Impact drill / Bohrhämmer / Дрель ударная / Дрель ударный / Útvefúró / Perforator de lovit / Přiklepová vrtačka / Přiklepová vrtačka / Udarni vrtnik / Grežtuvas su kalimu / Sitiēna urbjašina / Löökdrell / Бормашина ударна / Udarna bušilica / Udarna busilica / Κρουστικό δράπανο / Taladro de impacto / Trapano a percussione / Berbequim de impacto / Perceuse à choc / Slagboormachine



Ref.	L [mm]	H [mm]	[kg]	⊞	EAN
50G511	312	195	2,14	0/10	5902062505118



## WIERTARKA UDAROWA

Impact drill / Bohrhammer / Дрель ударная / Дрель ударный / Ütvefűró / Perforator de lovit / Příklepová vrtačka / Příklepová vrtačka / Udamni vrtnik / Grežtuvas su kalimu / Sitienu urbjmašina / Löökdrell / Бормашина ударна / Udamna bušilica / Udamna bušilica / Κρουστικό δράπανο / Taladro de impacto / Trapano a percussione / Berbequim de impacto / Perceuse à choc / Slagboormachine



Ref.	L [mm]	H [mm]	[kg]	⊞	EAN
50G852	353	255	3,25	0/5	5902062508522

## ΜΕΤΩΙΕΡΤΑΡΚΑ

Rotary Hammer Drill / Hammerbohrmaschine / Перфоратор / Перфоратор / Fúrókalapács / Ciocan rotatorcutor / Vrtači kladivo / Vrtacie kladivo / Vrtalno kladivo / Perforatorius / Perforators / Puurvasar / Перфоратор / Čekič-bušilica / Čekič-bušilica / Κρουστικό δράπανο / Martillo percutor / Martello perforatore / Martelo-Berbequim / Perceuse-marteau / Harmerboor



Ref.	L [mm]	H [mm]	[kg]	⊞	EAN
50G369	360	210	3,26	0/4	5902062503695

## WIERTARKO-MIESZARKA

Low speed drill / Bohr-Mischer / Дрель-миксер / Дрель низкооборотной / Festékkeverőgép / Perforator mic / Vrtačka-miřačka / Mieřač farby / Vrtnik/meřalnik / Grežtuvas - maisyklė / Urbjmašina mikseris / Drell (madala kiirusega) / Бормашина / Mikser u koferu / Busilica / Δράπανο χαμηλής ταχύτητας / Taladradora mezcladora / Trapano miscelatore / Berbequim-misturador / Perceuse-mélangeur / Boor-mixer



Ref.	L [mm]	H [mm]	[kg]	⊞	EAN
50G860	270	210	2,0	0/5	5902062508607

## ΜΕΤΩΙΕΡΤΑΡΚΑ

Hammer drill / Schlaghammer / Молоток отбойный / Перфоратор / Fúrókalapács / Perforator - ciocan de lovit / Kyvadlové kladivo / Skrutkovač AKU / Udamno kladivo / Perforatorius / Sitienu urbjmašina / Vasardrell / Къртач / Čekič bušilica / Hamer busilica / Κρουστικό δρεπάνι / Martillo de percusión / Martello demolitore / Martelo de impacto / Marteau à chocs / Slaghammer

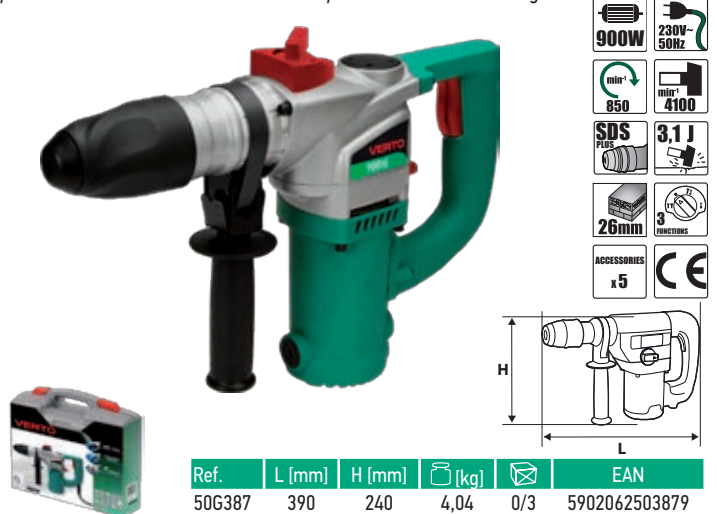

Ref.	L [mm]	H [mm]	[kg]	⊞	EAN
50G387	390	240	4,04	0/3	5902062503879

## ΜΕΤΩΙΕΡΤΑΡΚΑ

Rotary Hammer Drill / Hammerbohrmaschine / Перфоратор / Перфоратор / Fúrókalapács / Ciocan rotatorcutor / Vrtači kladivo / Vrtacie kladivo / Vrtalno kladivo / Perforatorius / Perforators / Puurvasar / Перфоратор / Čekič-bušilica / Čekič-bušilica / Κρουστικό δράπανο / Martillo percutor / Martello perforatore / Martelo-Berbequim / Perceuse-marteau / Harmerboor



Ref.	L [mm]	H [mm]	[kg]	⊞	EAN
50G365	340	210	2,25	0/5	5902062503657

## ΜΕΤΩΙΕΡΤΑΡΚΑ

Hammer drill / Schlaghammer / Молоток отбойный / Перфоратор / Fúrókalapács / Perforator - ciocan de lovit / Kyvadlové kladivo / Skrutkovač AKU / Udamno kladivo / Perforatorius / Sitienu urbjmašina / Vasardrell / Къртач / Čekič bušilica / Hamer busilica / Κρουστικό δρεπάνι / Martillo de percusión / Martello demolitore / Martelo de impacto / Marteau à chocs / Slaghammer



Ref.	L [mm]	H [mm]	[kg]	⊞	EAN
50G390	400	255	5,35	0/2	5902062503909

## SZLIFIERKA KĄTOWA

Angle grinder / Winkelschleifer / Шлифмашина угловая / Шліфмашина кутова / Sarokcsiszoló / Mašíná unghiulară de șlefuit / Bruska úhlová / Brúška uhlová / Kotni brusilnik / Kampinis šlifjuoklis / Leňka slípmášina / Nurklihvija / Ёглоулаіф / Brusilica kutna / Brusilica ugaona / Γωνιακός τροχός / Amoladora angular / Smerigliatrice angolare / Disco de limar p. cantos / Meuleuse d'angle / Versteckschuurmachine



Ref.	L [mm]	H [mm]	[kg]	⊠	EAN
51G052	265	105	1,6	0/6	5902062510532

## SZLIFIERKA KĄTOWA

Angle grinder / Winkelschleifer / Шлифмашина угловая / Шліфмашина кутова / Sarokcsiszoló / Mašíná unghiulară de șlefuit / Bruska úhlová / Brúška uhlová / Kotni brusilnik / Kampinis šlifjuoklis / Leňka slípmášina / Nurklihvija / Ёглоулаіф / Brusilica kutna / Brusilica ugaona / Γωνιακός τροχός / Amoladora angular / Smerigliatrice angolare / Disco de limar p. cantos / Meuleuse d'angle / Versteckschuurmachine



Ref.	L [mm]	H [mm]	[kg]	⊠	EAN
51G097	400	105	2,66	0/6	5902062512000

## SZLIFIERKA KĄTOWA

Angle grinder / Winkelschleifer / Шлифмашина угловая / Шліфмашина кутова / Sarokcsiszoló / Mašíná unghiulară de șlefuit / Bruska úhlová / Brúška uhlová / Kotni brusilnik / Kampinis šlifjuoklis / Leňka slípmášina / Nurklihvija / Ёглоулаіф / Brusilica kutna / Brusilica ugaona / Γωνιακός τροχός / Amoladora angular / Smerigliatrice angolare / Disco de limar p. cantos / Meuleuse d'angle / Versteckschuurmachine



Ref.	L [mm]	H [mm]	[kg]	⊠	EAN
51G091	290	65	1,8	0/6	5902062510969

## SZLIFIERKA KĄTOWA

Angle grinder / Winkelschleifer / Шлифмашина угловая / Шліфмашина кутова / Sarokcsiszoló / Mašíná unghiulară de șlefuit / Bruska úhlová / Brúška uhlová / Kotni brusilnik / Kampinis šlifjuoklis / Leňka slípmášina / Nurklihvija / Ёглоулаіф / Brusilica kutna / Brusilica ugaona / Γωνιακός τροχός / Amoladora angular / Smerigliatrice angolare / Disco de limar p. cantos / Meuleuse d'angle / Versteckschuurmachine



Ref.	L [mm]	H [mm]	[kg]	⊠	EAN
51G202	460	140	5,0	0/2	5902062512024

## SZLIFIERKA KĄTOWA

Angle grinder / Winkelschleifer / Шлифмашина угловая / Шліфмашина кутова / Sarokcsiszoló / Mašíná unghiulară de șlefuit / Bruska úhlová / Brúška uhlová / Kotni brusilnik / Kampinis šlifjuoklis / Leňka slípmášina / Nurklihvija / Ёглоулаіф / Brusilica kutna / Brusilica ugaona / Γωνιακός τροχός / Amoladora angular / Smerigliatrice angolare / Disco de limar p. cantos / Meuleuse d'angle / Versteckschuurmachine



Ref.	L [mm]	H [mm]	[kg]	⊠	EAN
51G098	390	85	2,3	0/6	5902062510983

## ZESTAW ELEKTRONARZĘDZI

Power tool set / Elektogeráteset / Набор электроинструментов / Набор електроінструменту / Elektromos szerszámkészlet / Set de scule electrice / Sada elektrického nářadí / Súprava elektrického nářadí / Komplet električnih orodij / Elektrinių įrankių komplektas / Elektroinstrumentu komplekts / Elektritööriistade komplekt / Комплект електроінструменту / Set elektricnih uređaja / Komplet elektrouredaja / Σετ ηλεκτρικών εργαλείων / Juego de herramientas eléctricas / Completo di elettrotrattenti / Kit de electroferramentas / Jeu d'outils électriques / Set van elektrogereedschap

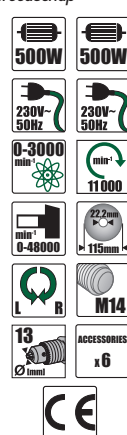

Ref.	⊠	EAN
52G105	0/4	590206251057

# VERTO

## WYRZYNARKA

Jigsaw / Ausschneidemaschine / Лобзик электрический / Лобзик / Dekorírfűrész / Ferástráu / Vyřezávací pila / Priamočiara pila / Vhodna žaga / Pjüklelis / Figürzágis / Jöhvsaaq / Трюон зеце / Ubodna Pila / Ubodna testera / Σέγα / Sierra de calar / Seghetto alternativo / Máquina de entalhar / Scie sauteuse / Decoupeerzaag





400W	230V-50Hz	0-45°	3000 min <sup>-1</sup>	55mm	5mm	ACCESSORIES x1	CE
------	-----------	-------	------------------------	------	-----	----------------	----

Ref.	L [mm]	H [mm]	[kg]	⊞	EAN
52G054	195	195	1,5	0/10	5902062520548

## WYRZYNARKA

Jigsaw / Ausschneidemaschine / Лобзик электрический / Лобзик / Dekorírfűrész / Ferástráu / Vyřezávací pila / Priamočiara pila / Vhodna žaga / Pjüklelis / Figürzágis / Jöhvsaaq / Трюон зеце / Ubodna Pila / Ubodna testera / Σέγα / Sierra de calar / Seghetto alternativo / Máquina de entalhar / Scie sauteuse / Decoupeerzaag

ELEKTRONARZÉDZIA / VERTO





570W	230V-50Hz	0-45°	0-3000 min <sup>-1</sup>	65mm	8mm	ACCESSORIES x1	CE
------	-----------	-------	--------------------------	------	-----	----------------	----

Ref.	L [mm]	H [mm]	[kg]	⊞	EAN
52G055	220	205	2,1	0/10	5902062520555

## WYRZYNARKA

Jigsaw / Ausschneidemaschine / Лобзик электрический / Лобзик / Dekorírfűrész / Ferástráu / Vyřezávací pila / Priamočiara pila / Vhodna žaga / Pjüklelis / Figürzágis / Jöhvsaaq / Трюон зеце / Ubodna Pila / Ubodna testera / Σέγα / Sierra de calar / Seghetto alternativo / Máquina de entalhar / Scie sauteuse / Decoupeerzaag



710W	230V-50Hz	0-45°	0-3000 min <sup>-1</sup>	80mm	10mm	ACCESSORIES x1	CE
------	-----------	-------	--------------------------	------	------	----------------	----

LASER	
-------	--

Ref.	L [mm]	H [mm]	[kg]	⊞	EAN
52G057	220	205	2,1	0/10	5902062520579

## PILARKA SZABLÓWA

Sabre saw / Motorstichsäge / Сабельная пила / Пилка шаблонна / Szablyafűrész / Ferástráu sabie / Šavlová pila / Chvostová pila / Sabljasta žaga / Tiesinis pjüklas / Zobenzágis / Saabelsaag / Сабельн трюон / Sabljasta pila / Sabljasta Testera / Σαβλόσαγα / Sierra de vaiven / Segá universale / Plaina / Scie à sabre / Sjabelzaag

650W	230V-50Hz	0-90°	500-3000 min <sup>-1</sup>	10mm	115mm	ACCESSORIES x2	CE
------	-----------	-------	----------------------------	------	-------	----------------	----

Ref.	L [mm]	H [mm]	[kg]	⊞	EAN
52G165	470	135	2,8	0/10	5902062521651

## SZLIFIERKA OSCYLACYJNA

Finishing sander / Vibrationsschleifmaschine / Вибрационная шлифовальная машина / Шлифмашина осциляционная / Vibrációs csiszoló / Masina de slefuit oscilatoare / Vibration brúska / Vibracíjski brusilnik / Ploktuminis šlifuoškis / Orbitalā šlīpmašīna / Taldlīhvija / Вибрационен шлайф / Vibracíjska brusilica / Oscilatorna brusilica / Παλμικό τριβείο / Lijadora orbital / Levigatrice orbitale / Disco de limar oscilante / Meuleuse oscillatoire / Oscillatie schuurmachine



135W	230V-50Hz	10000 min <sup>-1</sup>	2mm	187x90 (mm)	ACCESSORIES x1	CE
------	-----------	-------------------------	-----	-------------	----------------	----

Ref.	L [mm]	H [mm]	[kg]	⊞	EAN
51G320	235	160	1,2	0/10	5902062160652

## SZLIFIERKA OSCYLACYJNA

Finishing sander / Vibrationsschleifmaschine / Вибрационная шлифовальная машина / Шлифмашина осциляционная / Vibrációs csiszoló / Masina de slefuit oscilatoare / Vibration brúska / Vibracíjski brusilnik / Ploktuminis šlifuoškis / Orbitalā šlīpmašīna / Taldlīhvija / Вибрационен шлайф / Vibracíjska brusilica / Oscilatorna brusilica / Παλμικό τριβείο / Lijadora orbital / Levigatrice orbitale / Disco de limar oscilante / Meuleuse oscillatoire / Oscillatie schuurmachine





150W	230V-50Hz	10000 min <sup>-1</sup>	2mm	187x90 (mm)	ACCESSORIES x1	CE
------	-----------	-------------------------	-----	-------------	----------------	----

Ref.	L [mm]	H [mm]	[kg]	⊞	EAN
51G325	240	160	1,2	0/10	5902062513250

## SZLIFIERKA OSCYLACYJNA DELTA

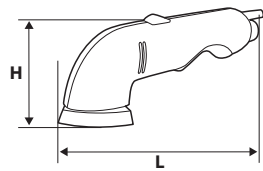
Finishing Sander / Schwingungsschleifer delta / Машина шлифовальная вибрационная / Шлифмашина дельтовидная / Rezsőcsiszoló / Slefuitor cu talpa / Vibrační delta bruska / Vibračná delta bruska / Vibracijski brusilnik delta / Sližuoklis „Delta“ / Lentas sliptmašina / Kolmurnaklihvija / Вибрационная шлайфмашина Делта / Oscilatorska brusilica delta / Oscilatorna brusilica delta / Παλμικό τριβείο / Lijadora orbital delta / Levigatrice a delta / Disco de limar oscilante delta / Meuleuse oscillatoire delta / Oscillatie deltaschuurmachine



Ref.	L [mm]	H [mm]	[kg]	⊠	EAN
51G308	335	120	1,2	0/10	5902062513083

## SZLIFIERKA MIMOŚRODOWA

Orbital sander / Exzenterschleifmaschine / Шлифмашина эксцентриковая / Шлифмашина ексцентрична / Dekopířez / Mašinà orbitalà de șlefuit / Excentrická bruska / Generator / Vibracijski brusilnik / Ekscentrinis šližuoklis / Sliptmašina ekscentriskà / Lihvimismasin / Шлайф машина / Vibraciona Brusilica / Vibraciona brusilica / Παλμικό τριβείο / Lijadora excentrica / Levigatrice rotoorbitale / Disco de limar / Meuleuse excentrique / Excenter schuurmachine

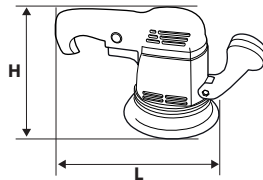

Ref.	L [mm]	H [mm]	[kg]	⊠	EAN
51G750	295	180	2,0	0/5	5902062517500

## SZLIFIERKA TAŚMOWA

Belt sander / Bandschleifmaschine / Шлифмашина ленточная / Шлифмашина стрічкова / Szalagcsiszoló / Strung de șlefuit cu bandă / Pásová bruska / Lešticka + prislúšenstvo / Траčni brusilnik / Juostinis šližuoklis / Lentas sliptmašina / Lintlihvija / Шлайф машина / Trakasta Brusilica / Trakasta brusilica / Λειαντήρας με ζώντα / Lijadora de banda / Levigatrice a nastro / Disco de limar de fita / Meuleuse à bande / Bandschuurmachine

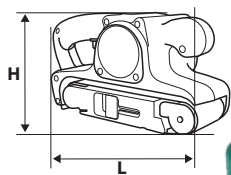

Ref.	L [mm]	H [mm]	[kg]	⊠	EAN
51G707	130	260	2,85	0/6	5902062517074

## STRUG

Planer / Hobel / Рубанок / Гембель / Gyalgúép / Gealäu / Hoblík / Hoblík / Skobeljnik / Oblus / Èvele / Höövel / Ренде / Blanjalica / Rende / Πλάνη / Cepillo / Pialla / Gartapa / Robot / Schaafmachine

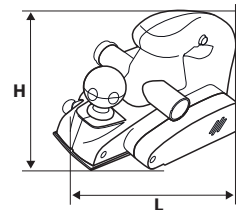

Ref.	L [mm]	H [mm]	[kg]	⊠	EAN
52G607	150	260	3,5	0/6	5902062526076

## NOŽE DO STRUGA

Cutters for planer / Messer für Hobel / Ножи к рубанку / Ножи до рубанка / Gyalgukések / Cuțite pentru rindea / Nože do hoblíku / Nože na hoblík / Rezila za oblič / Peilái obliui / Èveles naži / Höövliterad / Ножове за ренде / Noževi za blanju / Noževi struga / Λεπίδες πλάνης / Cuchillas para cepillo eléctrica / Lama per pialla / Facas p. Gartapa / Couteaux à robot / Bladen voor schaaftmachine



Ref.	L [mm]	[kg]	⊠	EAN
52G607-53	82	0,11	0/1	5902062526021

## FREZARKA

Router / Fräsmaschine / Станок фрезерный / Верстат фрезувальний / Felsőmaró / Trasator / Frézka / Fréza horná + prislúšenstvo / Rezkalnik / Freza / Fréze / Profilfreespínk / Фреза / Gladalica / Frezar / Φρέζα / Fresadora / Fresatrice / Fresa / Fraiseuse / Freesmchine

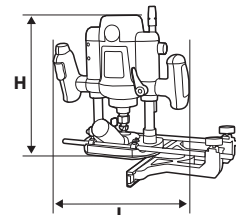

Ref.	L [mm]	H [mm]	[kg]	⊠	EAN
52G710	270	260	3,3	0/4	5902062527103

# VERTO

**OPALARKA**

Hot air gun / Sengmaschine / Термофен / Фен / Hőlégfúvó / Pistol de pulverizat aer cald / Opalovací stroj / Teplovzdušná pištoľ + príslušenstvo / Fen za vroči zrak / Techninis fenas / Fēns celtniecības / Куутарпур / Пистолет за горещ въздух / Fen za vroči zrak / Fen za vrelí vazduh / Πιστόλι θερμού αέρα / Decapador por aire caliente / Termosoffiatore / Soprador de ar quente / Décapeur thermique / Verfstripper

**DYSZE DO OPALARKI**

Nozzles for hot air gun / Sengmaschinendüsen / Conla κ θερμοφενу / Conla do фену / Tartozék hőlégfúvóhoz / Canule p/u pistoale-pulverizatoare de aer cald / Dýzy opalovacího stroje / Príslušenstvo / Nastavki za fen / Antgaliai techniniai fenui / Uzgalji celtniecības fēnam / Pihustid kuutարարի jaoks / Накрайники компл. / Nastavci za fen za vroči zrak / Nastavci za fen / Ακροφύσιο πιστολιού θερμού αέρα / Boquillas para decapadores por aire caliente / Ugelli per termosoffiatore / Bocais de soprador de ar quente / Buses de décapeur thermique / Mondstukken voor brander

**OPALARKA**

Hot air gun / Sengmaschine / Термофен / Фен / Hőlégfúvó / Pistol de pulverizat aer cald / Opalovací stroj / Teplovzdušná pištoľ + príslušenstvo / Fen za vroči zrak / Techninis fenas / Fēns celtniecības / Куутарпур / Пистолет за горещ въздух / Fen za vroči zrak / Fen za vrelí vazduh / Πιστόλι θερμού αέρα / Decapador por aire caliente / Termosoffiatore / Soprador de ar quente / Décapeur thermique / Verfstripper

**POLERKA**

Polisher / Poliermaschine / Машина полировальная / Машина полирувальна / Polírozógép / Dispozitiv șlefuire / Leštíčka / Brúška excentrická / Polirka / Poliruoklis / Pulētājs / Poleerimisvahend / Машина за полиране / Polir aparat / Polir aparat / Λεαντήρας / Pulidora / Lucidatrice / Aparelho polidor / Polisseuse / Polijstmaschine

**OPALARKA**

Hot air gun / Sengmaschine / Термофен / Фен / Hőlégfúvó / Pistol de pulverizat aer cald / Opalovací stroj / Teplovzdušná pištoľ + príslušenstvo / Fen za vroči zrak / Techninis fenas / Fēns celtniecības / Куутарпур / Пистолет за горещ въздух / Fen za vroči zrak / Fen za vrelí vazduh / Πιστόλι θερμού αέρα / Decapador por aire caliente / Termosoffiatore / Soprador de ar quente / Décapeur thermique / Verfstripper

**SZLIFIERKA STOŁOWA**

Bench grinder / Tis Schlesifmaschine / Машина шлифовальная настольная / Шлифмашина верстатна / Kőszörűgép / Utilaj de șlefuit / Stolní bruska / Brúška stolová / Namizni brusilnik / Stacionarus šlifuoelis / Galda slípmášina / Lihvimispink / Шмурел / Dvostrano točilo / Dvostrano točilo / Τροχός επιτραπέζιος / Amoladora de banco / Smerigliatrice da banco / Disco de limar de mesa / Meuleuse d'établi / Tafelschuurmachine

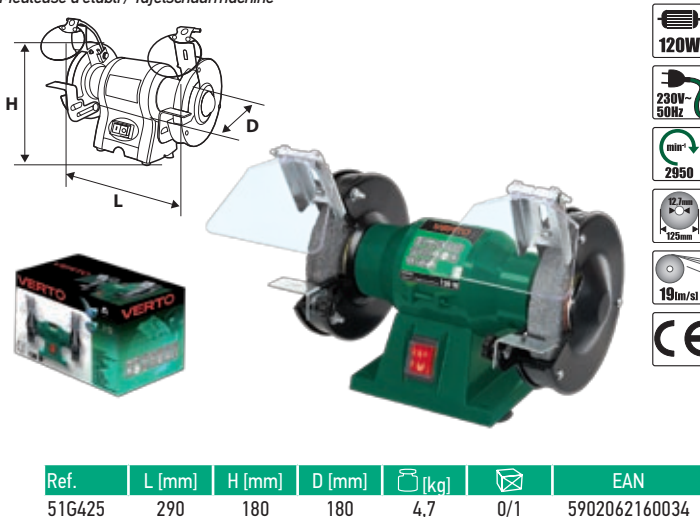

## SZLIFIERKA STOŁOWA

Bench grinder / Tischnschleifmaschine / Машина шлифовальная настольная / Шліфмашина верстатна / Köszörűgép / Utílaj de șlefuit / Stolní bruska / Brúska stolová / Namizni brusilnik / Stacionarus šljufoklis / Galda slipmašina / Lihvimispink / Шмупзел / Dvostrano točilo / Dvostrano točilo / Τροχός επιτραπέζιος / Amoladora de banco / Smerigliatrice da banco / Disco de limar de mesa / Meuleuse d'établi / Tafelschuurmachine

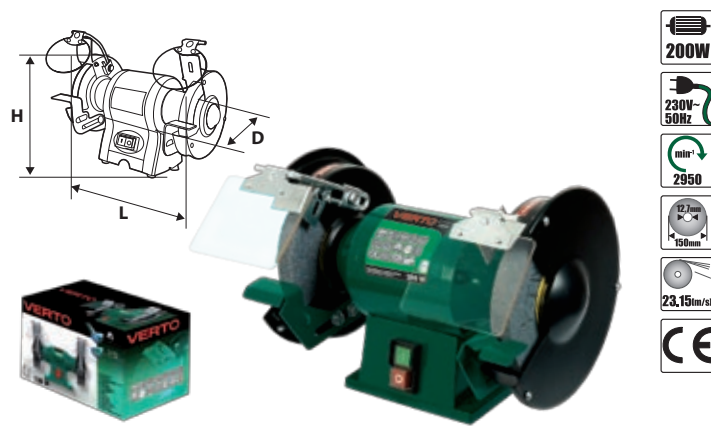

Ref.	L [mm]	H [mm]	D [mm]	[kg]	⊠	EAN
51G450	330	215	195	7,5	0/1	5902062160041

## SZLIFIERKA STOŁOWA

Bench grinder / Tischnschleifmaschine / Машина шлифовальная настольная / Шліфмашина верстатна / Köszörűgép / Utílaj de șlefuit / Stolní bruska / Brúska stolová / Namizni brusilnik / Stacionarus šljufoklis / Galda slipmašina / Lihvimispink / Шмупзел / Dvostrano točilo / Dvostrano točilo / Τροχός επιτραπέζιος / Amoladora de banco / Smerigliatrice da banco / Disco de limar de mesa / Meuleuse d'établi / Tafelschuurmachine



Ref.	L [mm]	H [mm]	D [mm]	[kg]	⊠	EAN
51G427	325	250	255	9,8	0/1	5902062514271

## SZLIFIERKO-OSEŁKA STOŁOWA

Wet-dry bench grinder / Tischnschleif- und Schärfmaschine / Станок шлифовально-точильный / Шліфмашина верстатна / Köszörűgép / Strung de șlefuit umed-uscăt / Bruska na mokro / sucho stolní / Brúska stolová kombinovaná / Namizni brusilnik / Stacionarus šljufoklis, sausam / šliapami šljufavimui / Galda slipmašina / Kuiv-märg lihvimispink / Шмупзел / Dvostrano točilo / Dvostrano točilo / Επιτραπέζιος τροχός ακονίσματος / Esmeriladora de banco / Smerigliatrice da banco combinata / Disco de limar, polir de mesa / Meuleuse d'établi à aiguiser / Tafelschuur-slijpmachine

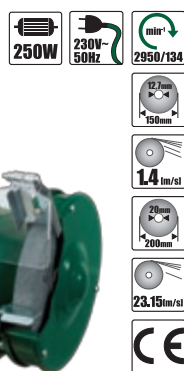
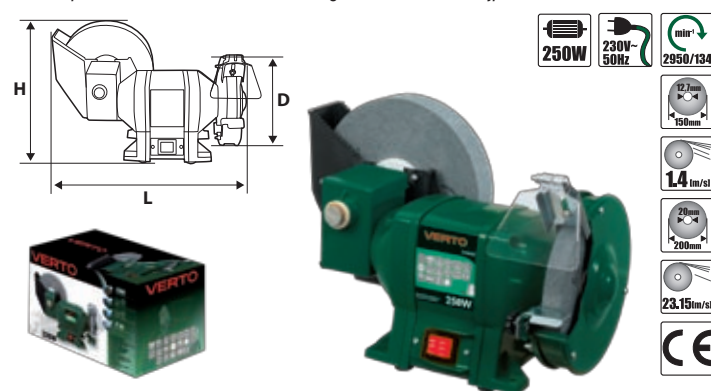

Ref.	L [mm]	H [mm]	D [mm]	[kg]	⊠	EAN
51G452	290	180	260	12,0	0/1	5902062514523

## PILARKA TARCZOWA

Circular saw / Kreissäge / Пила дисковая / Пилка циркулярна / Körfűrész / Ferestră circular / Kotoučová pila / Pila kotučová / Krožna žaga / Diskinis pjūklas / Cirkulāržāģis / Kreissaag / Циркуляр / Kružna Pila / Kruzna testera / Διακοπτήριο / Sierra circular / Sega circolare / Plainade disco / Scie circulaire / Schijfzaag

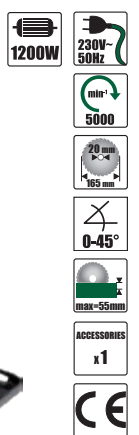

Ref.	L [mm]	H [mm]	[kg]	⊠	EAN
52G682	265	220	3,2	0/4	5902062526823

## PILARKA TARCZOWA

Circular saw / Kreissäge / Пила дисковая / Пилка циркулярна / Körfűrész / Ferestră circular / Kotoučová pila / Pila kotučová / Krožna žaga / Diskinis pjūklas / Cirkulāržāģis / Kreissaag / Циркуляр / Kružna Pila / Kruzna testera / Διακοπτήριο / Sierra circular / Sega circolare / Plainade disco / Scie circulaire / Schijfzaag

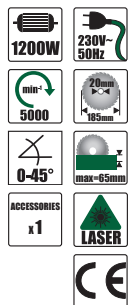

Ref.	L [mm]	H [mm]	[kg]	⊠	EAN
52G684	280	240	3,52	0/4	5902062526847

## PILARKA UKOSOWA

Mitre saw / Schrägsäge / Пила торцовочная / Пила-стусло / Gértvágógép / Ferestră tăiere sub înghi / Pokosová pila / Pila pokosová s laserom / Krožna žaga / Stacionarus pjūklas / Lenka žāģis / Kaldsaag / Циркуляр / Kružna Pila / Kruzna testera / Διακοπτήριο / Inglețadora / Troncatrice radiale / Plaina inclinada / Scie à chanfreiner / Verstekzaag



Ref.	L [mm]	H [mm]	D [mm]	[kg]	⊠	EAN
52G206	340	455	395	7,95	0/1	5902062522061

**VERTO**

## PILARKA DO GLAZURY

Tile cutter / Fliesensäge / Плиткорез электрический / Плиткоріз електричний / Cseprengőgép / Tájtor placă / Pila na glazuru / Rezačka dlažby stolová / Žaga za ploščice / Plytelij pjaustyklië / Flizgriezëjs / Plaadilõikur / Циркуляр / Pila za ploščice / Stona testera / Κόφτης πλακιδίων / Cortador eléctrico de azulejos / Tagliapiastrelle elettrico / Plaina p. Azulejos / Scie à carrelage / Glazuurzaag

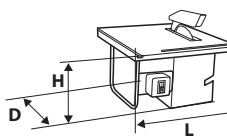

Ref.	L [mm]	H [mm]	D [mm]	kg [kg]	0/1	EAN
52G280	360	170	330	8,1	0/1	5902062522801

## WIERTARKA KOLUMNOWA

Drill Press / Säulenbohrmaschine / Станок сверлильный / Верстат сверлильний / Oszlopforásgép / Mašinã de găurit montatã pe coloanã / Sloupcová vrtačka / Sítrovã vrtačka / Stebni vrtnik / Grežimo staklës, stacionarios / Urbšanas darbgalds / Пулпінк / Колонна бормашина / Stupna bušilica / Stubna bušilica / Κατακόρυφο δρέπανο / Taladro de columna / Trapano a colonna / Berbequim de coluna / Perceuse de colonne / Kolomboormachine

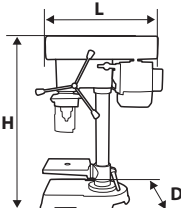

Ref.	L [mm]	H [mm]	D [mm]	kg [kg]	0/1	EAN
50G934	400	570	185	20,3	0/1	5902062509345

## МУЖКА ЦІСНІЕНІОВА

High pressure cleaner / Druckreiniger / Мойна високогог давления / Мийна під тиском / Magasnyomású mosó / Mašinã de spãlat sub presiune / Vysokotlaký čistìč / Tlakovã vodnã čistìčka / Visokotlačni čistilec / Slëginis indas / Augstspiediena mazgãtne / Survepesur / Мивна под налягане / Tlačni čistãč / Cistãč pod pritiskom / Πιεστικό / Limpiadora de presiõn / Idropulitrice / Aparelho de lavar de pressão / Nettoyeur à eau haute pression / Drukreiniger

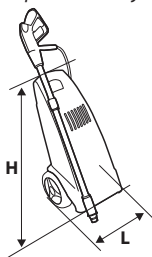

Ref.	L [mm]	H [mm]	kg [kg]	0/1	EAN
52G418	260	515	4,5	0/1	5902062524188

## REKOEJÉC PISTOLETOWA Z PRZEWODEM DO MYJKI CIŚNIENIOWEJ

Gun handle with pressure hose for pressure washer / Pistolengriff mit Hochdruckschlauch für Hochdruckreiniger / Рукòятна пистолетного тина с напорным шлангом для мойщего аппарата высокого давления / Рукòяч пистолетне зі шлангом до мийки високого тиску / Pisztolymarkolat magasnyomású tömlővel magasnyomású mosóhoz / Mánier tip pistol cu furtun de presiune pentru maşina de spãlat / Rukojeť pistole s tlakovou hadicou pro vysokotlaký čistìč / Pistolová rukovãt s tlakovým potrubím do tlakovej umývãčky / Pištolni ročaj s tlačno cevjo za visokotlačni čistilec / Purškimo pistoletas su aukšto slëgio žarna, aukšto slëgio plovimo įrenginiui / Pistoles rokturis ar spiedienvadu spiediena mazgãtãjam / Survevolikuga püstolkãepide survepesurile / Рукòхватка на прьснача с трьбопровод под налягане за водоструйна / Rukohvat pistolja s tlačnim vodom za visokotlačni čistãč / Pištolj drška sa kablom za pritisak za čistãč pod pritiskom / Kãvny me eúκαμπο σωλήνα υψηλής πίεσης για το πλυστικό µηχãνµια υψηλής πίεσης / Empuñadura de pistola con cable de presiõn para limpiadora a presiõn / Impugnatura a pistola con tubo ad alta pressione per idropulitrice / Pega de pistola com mangueira de pressão para lavadora de alta pressão / Poignée pistolet avec flexible haute pression pour le nettoyeur haute pression / Pistoollhandvat met leiding voor drukreiniger



Ref.	0/20	EAN
52G418-180	0/20	5902062484130

## ZBIORNIK NA DETERGENT DO MYJKI CIŚNIENIOWEJ

Detergent tank for pressure washer / Reinigungsmittelbehälter für Hochdruckreiniger / Емкость для мойщего средства, для мойщего аппарата высокого давления / Емнìсть для детергенту до мийки високого тиску / Mosászertartály magasnyomású mosóhoz / Recipient pentru detergent pentru maşina de spãlat / Nãdobka na čistiaci prostriedek pro vysokotlaký čistìč / Nãdoba na čistiaci prostriedok do tlakovej umývãčky / Posoda za detergent za visokotlačni čistilec / Bakas chemikalams, aukšto slëgio plovimo įrenginiui / Mazgãšanas līdzekļa tvertne spiediena mazgãtãjam / Pesuainetahuti survepesurile / Резервоар за детергент за водоструйна / Spremnik za deterdžent za visokotlačni čistãč / Rezervoar za deterdžent za čistãč pod pritiskom / Δοχείο απορριπταντικού για το πλυστικό µηχãνµια υψηλής πίεσης / Depõsito para detergente para limpiadora a presiõn / Serbatoio del detergente per idropulitrice / Depõsito de detergente para lavadora de alta pressão / Réservoir de deterdžent pour le nettoyeur haute pression / Bak voor detergent voor drukreiniger



Ref.	0/1	EAN
52G418-307	0/1	5902062484123

## МУЖКА ЦІСНІЕНІОВА

High pressure cleaner / Druckreiniger / Мойна високогог давления / Мийна під тиском / Magasnyomású mosó / Mašinã de spãlat sub presiune / Vysokotlaký čistìč / Tlakovã vodnã čistìčka / Visokotlačni čistilec / Slëginis indas / Augstspiediena mazgãtne / Survepesur / Мивна под налягане / Tlačni čistãč / Cistãč pod pritiskom / Πιεστικό / Limpiadora de presiõn / Idropulitrice / Aparelho de lavar de pressão / Nettoyeur à eau haute pression / Drukreiniger

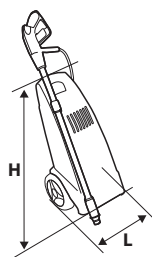

Ref.	L [mm]	H [mm]	kg [kg]	0/1	EAN
52G423	270	735	6,0	0/1	5902062524232

## RĘKOJEŚĆ PISTOLETOWA DO MYJKI CIŚNIENIOWEJ

Gun handle for pressure washer / Pistolenriff mit Hochdruckschlauch für Hochdruckreiniger / Ружьятка пистолетного типа для мойщего аппарата высокого давления / Ружья пистолетне до мойки високого тиску / Pisztolymarkolat magasnyomású mosóhoz / Månier tip pistol pentru maşina de spălat / Rukojeť pistole pro vysokotlaký čistič / Pištolová rukoväť do tlakovej umývačky / Pištolni ročaj za visokotlačni čistilec / Purškimo pistoletas, aukšto slėgio plovimo įrenginiui / Pistoles rokturis spiediena mazgātājam / Püistolikäepide survepesurile / Ружьхватка на пружкача за водоструйка / Rukohvat pistolja za visokotlačni čistač / Pištolj drška za čistač pod pritiskom / Κάβη για το πλαστικό μηχανήμα υψηλής πίεσης / Επιρρηadura de pistola para limpiadora a presión / Impugnatura a pistola per idropulitrice / Pega de pistola para lavadora de alta pressão / Poignée pistolet pour le nettoyeur haute pression / Pistoolhandvat voor drukreiniger



Ref.	☒	EAN
52G423-180	0/24	5902062484246

## PRZEWÓD CIŚNIENIOWY DO MYJKI CIŚNIENIOWEJ

Pressure hose for pressure washer / Pistolenriff für Hochdruckreiniger / Напорный шланг для мойщего аппарата высокого давления / Шланг до мойки високого тиску / Magasnyomású tömlő magasnyomású mosóhoz / Furtun de presiune pentru maşina de spălat / Tlaková hadice pro vysokotlaký čistič / Tlakové potrubie do tlakovej umývačky / Tlačná cev za visokotlačni čistilec / Aukšto slėgio žarna, aukšto slėgio plovimo įrenginiui / Spiedienvads spiediena mazgātājam / Surveoolik survepesurile / Тръбнопровод под налягане за водоструйка / Tlačni vod za visokotlačni čistač / Kabel za pritisk za čistač pod pritiskom / Εύκαμπτος σωλήνας υψηλής πίεσης για το πλαστικό μηχανήμα υψηλής πίεσης / Cable de presión para limpiadora a presión / Tubo ad alta pressione per idropulitrice / Mangueira de pressão para lavadora de alta pressão / Flexible haute pression pour le nettoyeur haute pression / Drukleiding voor drukreiniger



Ref.	☒	EAN
52G423-182	0/24	5902062484253

## LANÇA

Lance / Lanze / Удлинительная штанга / Пика / Szórászár / Lance / Násadec / Dýza / Šoba / Jungtis / Asmens / Püistolkäepidemeņa piik / Konue / Lanca / Lula / Μπάρα προέκτασης / Lanza / Lancia / Lança / Lance / Lans



Ref.	☒	EAN
52G418-75	0/62	5902062484147
52G423-75	0/100	5902062484260

## POMPA ZANURZENIOWA

Submersible pump / Tauchpumpe / Погружной насос / Pompa zagłębna / Búvárszivattyú / Pompa de fundare / Ponomé čerpadlo / Ponomé čerpadlo / Potorna črpalka / Panardinamas siurblys / Iegremdējamais sūknis / Sukelpump / Подводна помпа / Potorna pumpa / Potorijena pumpa / Καταβύομενη αντλία / Bomba de inmersión / Pompa a immissione / Bomba de imersão / Pompe immergée / Dompelpomp

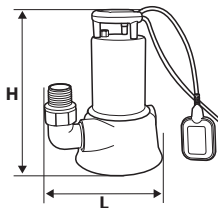

250W	230V-50Hz
5000 l/h	h max 5m
h max 5m	10m
3x1mm <sup>2</sup>	max 35 T(°C)
IP68	CE

Ref.	L [mm]	H [mm]	☒ [kg]	☒	EAN
52G450	155	285	3,8	0/4	5902062524508

## POMPA ZANURZENIOWA

Submersible pump / Tauchpumpe / Погружной насос / Pompa zagłębna / Búvárszivattyú / Pompa de fundare / Ponomé čerpadlo / Ponomé čerpadlo / Potorna črpalka / Panardinamas siurblys / Iegremdējamais sūknis / Sukelpump / Подводна помпа / Potorna pumpa / Potorijena pumpa / Καταβύομενη αντλία / Bomba de inmersión / Pompa a immissione / Bomba de imersão / Pompe immergée / Dompelpomp

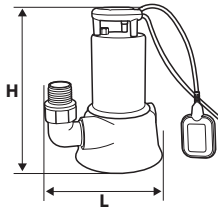

400W	230V-50Hz
7500 l/h	h max 5m
h max 5m	10m
3x1mm <sup>2</sup>	max 35 T(°C)
IP68	CE

Ref.	L [mm]	H [mm]	☒ [kg]	☒	EAN
52G440	170	315	4,1	0/4	5902062524409

## POMPA ZANURZENIOWA

Submersible pump / Tauchpumpe / Погружной насос / Pompa zagłębna / Búvárszivattyú / Pompa de fundare / Ponomé čerpadlo / Ponomé čerpadlo / Potorna črpalka / Panardinamas siurblys / Iegremdējamais sūknis / Sukelpump / Подводна помпа / Potorna pumpa / Potorijena pumpa / Καταβύομενη αντλία / Bomba de inmersión / Pompa a immissione / Bomba de imersão / Pompe immergée / Dompelpomp

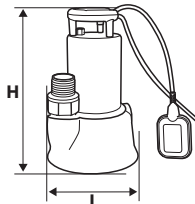

810W	230V-50Hz
11500 l/h	h max 8m
h max 8.5m	10m
3x1mm <sup>2</sup>	max 35 T(°C)
IP68	CE

Ref.	L [mm]	H [mm]	☒ [kg]	☒	EAN
52G448	205	345	5,3	0/4	5902062504487

**VERTO**



## POMPA OGRODOWA

Garden pump / Gartenpumpe / Насос садовый / Kerti szivattyú / Pompa de gradina / Zahradní čerpadlo / Záhradné čerpadlo / Vrtna črpalka / Sodo siurblys / Dārza sūkņis / Aiarump / Градинска помпа / Vrtna pumpa / Baštenska pumpa / Αντλία κηπου / Bomba de jardin / Pompa da giardino / Bomba de jardim / Pompe de jardin / Tuinpomp



Ref.	L [mm]	H [mm]	[kg]	⊞	EAN
52G460	230	460	7,7	0/1	5902062504609

## PILARKA ŁAŃCUCHOWA

Chain saw / Kettensägemaschine / Пила цепная электрическая / Пилка ланцюгова / Láncfűrész / Ferästräu cu lanț / Řetězová píla / Verižna žaga / Grandininis pjūklas / Kēdes zāģis / Kettesaag / Вержен трион / Lančana píla / Lančana testera / Ηλεκτρικό αλυσοπίο / Sierra de cadena / Segá a catena / Plaina de corrente / Scie à chaîne / Kettingzaag

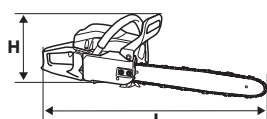

Ref.	L [mm]	H [mm]	[kg]	⊞	EAN
52G584	810	195	5,55	0/2	5902062505842

## OSTRZAŁKA DO ŁAŃCUCHÓW

Chain sharpener / Kettenschärfgerät / Точилка для цепи бензопилы / Пристосування для гостріння пильних ланцюгов / Láncélező / Masina de ascuțit lanturi / Ostřička řetězů / Brúška na řetaze / Brusilnik za verige / Galastuvās grandīnei / Kēdes asinātājs / Ketīteritaja / Заточивача машинна за вериги / Oštrač lanca / Oštrač za lanac / Ακονιστήρι αλυσίδας βενζινοκίνητου αλυσοπίου / Afilador de cadena / Affilcatene per motosega ed elettrosega / Afiaador de correntes / Affûtuse de chaîne / Kettingslijper

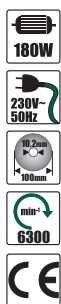

Ref.	L [mm]	H [mm]	[kg]	⊞	EAN
52G502	360	160	2,1	0/4	5902062525024

## ŁAŃCUCH DO PILARKI ŁAŃCUCHOWEJ

Chain for chain saw / Kettensägekette / Цепь для цепной пилы / Ланцюг до пилки ланцюгової / Láncfűrész lánc / lanț p/u ferăsträu cu lanț / Řetěz řetězové pily / Řetěz na řetězovou pílu / Veriga za verižno žago / Grandinė grandininiam pjūklui / Kēde ķēžu zāģim / Kettisae kett / Вержен цупруглар / Lanac za lančanu pílu / Lanac za električnu testera / Αλυσίδα / Cadena para sierra de cadena / Catena per sega a catena / Corrente para serra de motor / Chaîne pour scie à chaîne / Ketting voor kettingzaag



Ref.	[kg]	⊞	EAN
52G584-71	0,18	0/12	590206222244

## PROWADNICA DO PILARKI ŁAŃCUCHOWEJ

Sword for chain saw / Kettensägeführung / Направляющая к пиле / Шина напрямна до пилки ланцюгової / Kardfűrész / Spadă ferăsträu cu lanț / Vodící lišta řetězové pily / Lišta Oregon pre / Meč za verižno žago / Kreipiančioji grandininiam pjūklui / Sliede ķēžu zāģim / Kettisae löikur / Шина за Резачка / Remen za električnu pílu / Remen za električnu testera / Οδηγός σιματαιού για αλυσοπίο / Guía para sierra de cadena / Guida per la sega a catena / Guias de motosegura / Guidage pour scie à chaîne / Geleider voor kettingzaag



Ref.	L [mm]	⊞	EAN
52G584-73	405	0/1	590206222237

## NOŻYCE DO ŻYWORĘLOTU

Hedge shears / Heckenschere / Ηοζκνιци для живοї υζγορoди / Ηοζκνιци до живοпoтлy / Sövényvágó olló / Foarfece grădini / Nůžky na živý plot / Nožnice na živý plot / Škarje za živo mejo / Zirkklés gyvatvorei / Gneznes krūmiem / Hekikäärid / Ηοζκνιца за χροστυ / Skare za živu ogradu / Makaze za živu ogradu / Ψαλίδι για φράκτη από θάμνους / Cortasetos eléctrica / Tagliasiepi elettrica / Tesoura p. Vedação / Cisaille à haie / Hekscharen

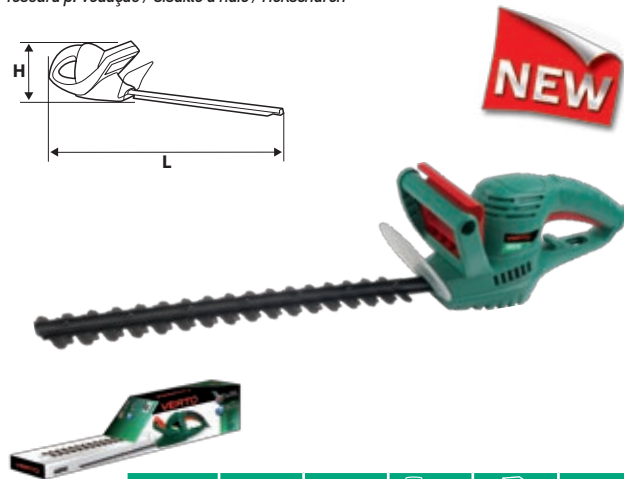
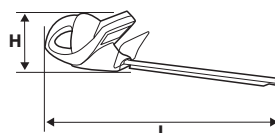

Ref.	L [mm]	H [mm]	[kg]	⊞	EAN
52G567	830	185	2,45	0/1	5902062505675

## NOŻE

Blades / Schere / Ηοζκνι / Ηοζκνι / Kések / Cutite / Nože / Čepele / Noži / Peiliai / Naži / Noad / Ηοζκoε / Noževi / Noževi / Μαχαίρια / Cuchillos / Forbici / Facas / Couteaux / Bladen

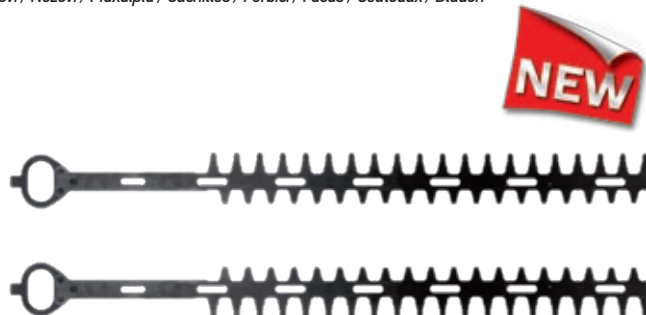

Ref.	⊞	EAN
52G567-30	0/10	5902062484338

## KOSIARKA DO TRAWY

Lawn mower / Rasenmäher / Газонокосилка / Газонокосарка / Fűnyíró / Cositoare gazon / Sekačka na trávu / Kosačka na trávu / Kosilnica za travo / Vejarjovë / Zăles plajmașina / Muruniiduk / Косачка за трева / Kosilica za travu / Kosilica za travu / Χλοοκοπτικό μηχανήμα / Cortacésped / Falciatrice da prato / Ceifeira para relva / Tondeuse à gazon / Grasmaaier



Ref.	L [mm]	D [mm]	Ⓜ [kg]	📦	EAN
52G572	980	375	8,3	0/1	5902062505729

## NÓZ DO KOSIARKI

Lawn mower blade / Messer für Rasenmäher / Нож для газонокосилки / Ніж до газонокосарки / Vágókés fűnyíróhoz / Cuțit de cositoare / Nůž do sekačky / Nůž do kosačky / Rezilo za kosilnico / Peilis žoliarjovëi / Nazis plajmașinari / Niidukitera / Нож за косачка / Nož za kosilicu / Nož za kosilicu / Λεπίδα χλοοκοπτικής μηχανής / Hoja para cortacésped / Mes voor grasmaaier

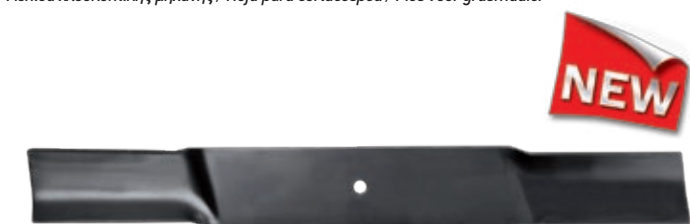

Ref.	L [mm]	Ⓜ [kg]	📦	EAN
52G572-30	320	0,27	0/50	5902062484345

## PASEK NAPĘDOWY DO KOSIARKI DO TRAWY

Driving belt for lawn mower / Antriebsriemen für Rasenmäher / Приводной ремень для газонокосилки / Ремінь ведучий для газонокосарки / Hajtósíj fűnyírógéphez / Curea de acționare pentru cositoare de iarbă / Hnací řemen pro sekačku na trávu / Pohonný remeň do kosačky na trávu / Pogonski jermen za kosilnico za travo / Varomasis diržas žoliarjovëi / Dzensiksna zăles plăvețam / Mootoririhm muruniidukile / Задвижущий ремень за косачка за трева / Pogonski remen za kosilicu za travu / Naponski kaiš za kosilicu za travu / Ιμάντας μετάδοσης κίνησης για τη χλοοκοπτική μηχανή / Correa de transmisión para cortacésped / Cinghia di trasmissione per rasaerba / Correia de transmissão para corta-relvas / Courroie d'entraînement pour tondeuse pour herbe / Aandrijriem voor grasmaaier



Ref.	Ⓜ [kg]	📦	EAN
52G572-31	0,8	0/20	5902062484352

## KOSA SPALINOWA

Petrol grass cutter / Motorsense / Бензокоса / Косарка бензинова / Motoros fűkasza / Cositoare cu motor cu ardere internă / Benzinová kosa / Benzinová kosa / Motorna kosa / Benzininė žoliarjovë (trimeris) / Trimmeris ar iekšdedzes dzinēju / Bensiniimootoriga trimmer / Моторна коса / Benzinski trimmer / Kosa sa unutrašnjim sagorevanjem / Βενζινοκίνητη χλοοκοπτική μηχανή / Motoguadaña / Decespugliatore a scoppio / Segadeira de combustão / Faux à essence / Motorzeis



Ref.	L [mm]	H [mm]	Ⓜ [kg]	📦	EAN
50G490	370	1860	7,5	0/1	5902062524904

## NÓZ DO KOSY SPALINOWEJ

Lawn mower blade / Messer für Rasenmäher / Нож для газонокосилки / Ніж до газонокосарки / Vágókés fűnyíróhoz / Cuțit de cositoare / Nůž do sekačky / Nůž do kosačky / Rezilo za kosilnico / Peilis žoliarjovëi / Nazis plajmașinari / Niidukitera / Нож за косачка / Nož za kosilicu / Nož za kosilicu / Λεπίδα χλοοκοπτικής μηχανής / Hoja para cortacésped / Mes voor motorzeis



Ref.	📦	EAN
50G490-30	0/1	5902062183057

## ŽYŁKA DO KOSY SPALINOWEJ

Cutting line for petrol grass cutter / Schneideseil für Motorsense / Леска для бензокосы / Струна до мотокошы / Vágósíj motoros fűkaszához / Fir tăietor pentru cositoare / Struna do benzinové kosy / Zacia struna do benzinovej kosačky / Nitka za bencinsko kosilnico / Valas pjūklui su vidaus degimo varikliu / Dzisla iekšdedzes trimmerim / Murutrimmeri jöhv / Κορδα за бензинова косачка / Rezna nit za benzinsku kosilicu / Žilica za kosu sa unutrašnjim sagorevanjem / Μεταίεζα βενζινοκίνητου χλοοκοπτικού / Hilo de nilón para motoguadaña / Filo per tagliaerba / Linha para ceifeira / Fil à coupeur d'herbes / Lijn voor motorzeis



Ref.	📦	EAN
50G490-134	0/1	5902062183040

**VERTO**

**ODKURZACZ OGRODOWY**

Garden vacuum / Gardenstaubsauger / Пылесос садовый / Пилосос садовничий / Lombszívó / Suflantă de grădină (curățare de frunze) / Zahradní vysavač / Záhradný vysávač / Vrtni sesalnik / Sodo siurblys / Dārza putekļsūcējs / Leheimur / Градінська прахосмукачка / Vrtni usisavač / Baštenski usisivač / Αναρροφητήρας κήπου / Aspirador de jardín / Aspiratore da giardino / Aspirador para jardim / Aspirateur de jardin / Tuinstofzuiger



Ref.	L [mm]	H [mm]	W [mm]	[kg]	⊞	EAN
52G500	810-1110	230	175	3,15	0/1	5902062505002

**DMUCHAWA ELEKTRYCZNA**

Electric blower / Elektrisches Gebläse / электровздухувачка / Повітродувка електрична / Elektromos szívó-fúvó készülék / Suflantă electrică / elektrické dmychadlo / Elektrické duchadlo / Električni puhalnik / Elektrinis pūstuvas / Elektriskais gaisa rūtējs / Elektriline puhur / вздухувачка / elektricko puhalo / usisavač / Elektrická dunačica / Ηλεκτρικός φυσητήρας / Soplador eléctrico / Soffiatore aspiratore elettrico / Soprador elétrico / Souffleur électrique / Elektrische blazers



Ref.	L [mm]	H [mm]	W [mm]	[kg]	⊞	EAN
52G505	205	170	185	1,5	0/8	5902062525055

**KOMPRESOR OLEJOWY**

Compressor - lubricated / Ölkompressor / Компрессор масляный / Компрессор олійний / Kompresszor / Compressor unsoare / Olejový kompresor / Kompresor / Oljni kompresor / Tepalínis kompresorius / Eļļas kompresors / Kompresor (määritud) / Kompresor / Kompresor / Συμπιεστής γρασαρίματος / Compressor de aceite con propulsión directa / Compresore ad olio / Compressor de óleo / Compresseur à huile / Olie compressor

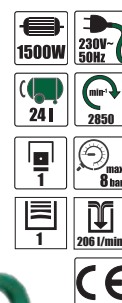
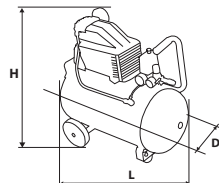

Ref.	L [mm]	H [mm]	W [mm]	[kg]	⊞	EAN
73K002	570	560	250	26	0/1	5902062730022

**KOMPRESOR OLEJOWY**

Compressor - lubricated / Ölkompressor / Компрессор масляный / Компрессор олійний / Kompresszor / Compressor unsoare / Olejový kompresor / Kompresor / Oljni kompresor / Tepalínis kompresorius / Eļļas kompresors / Kompresor (määritud) / Kompresor / Kompresor / Συμπιεστής γρασαρίματος / Compressor de aceite con propulsión directa / Compresore ad olio / Compressor de óleo / Compresseur à huile / Olie compressor

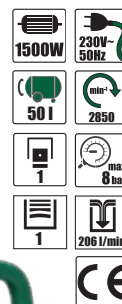
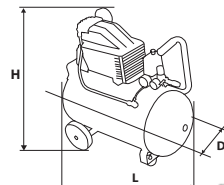

Ref.	L [mm]	H [mm]	D [mm]	[kg]	⊞	EAN
73K004	710	620	300	31	0/1	5902062730046

## WIERTŁO DO METALU

Metal drills / Metallbohrer / Свёрла по металлу / Свёрла по металлу / Fémfúró / Burghie pentru metale / Vrtáky do kovu / Vrtáky do kovu / Svedri za kovino / Gražtai metalui / Urbis metálam / Metallipuur / Свёрла за метал / Svrđla za metal / Burgija za metal / Τρυπάνια μετάλλου / Brocas para metal / Punta per metallo / Brocas p. metal / Forêts à métal / Boor voor metaal

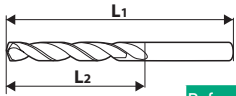

Ref.	Ø [mm]	L1	L2	☒	EAN
60H070	1.0	34	12	10/8000	5902062600707
60H071	1.5	40	18	10/8000	5902062600714
60H072	2.0	49	24	10/8000	5902062600721
60H073	2.5	57	30	10/8000	5902062600738
60H074	3.0	61	33	10/8000	5902062600745
60H075	3.2	65	36	10/8000	5902062600752
60H076	3.5	70	39	10/4000	5902062600769
60H077	4.0	75	43	10/4000	5902062600776
60H078	4.2	75	43	10/4000	5902062600783
60H079	4.5	80	47	10/2500	5902062600790
60H080	5.0	86	52	10/2500	5902062600806
60H097	5.2	86	52	10/2500	5902062600974
60H081	5.5	93	57	10/2500	5902062600813
60H082	6.0	93	57	10/2000	5902062600820
60H083	6.5	101	63	10/1200	5902062600837
60H084	7.0	109	69	10/1200	5902062600844
60H085	7.5	109	69	10/1000	5902062600851
60H086	8.0	117	75	5/600	5902062600868
60H087	8.5	117	75	5/600	5902062600875
60H088	9.0	125	81	5/600	5902062600882
60H089	9.5	125	81	5/600	5902062600899
60H090	10.0	133	87	5/350	5902062600905
60H091	10.5	133	87	5/350	5902062600912
60H092	11.0	142	94	5/300	5902062600929
60H093	11.5	142	94	5/300	5902062600936
60H094	12.0	151	101	5/300	5902062600943
60H095	12.5	151	101	5/300	5902062600950
60H096	13.0	151	101	5/300	5902062600967
60H074_1	3.0	61	33	1/20	5902062601001
60H077_1	4.0	75	43	1/20	5902062601018
60H078_1	4.2	75	43	1/20	5902062601025
60H079_1	4.5	80	47	1/20	5902062601032
60H080_1	5.0	86	52	1/20	5902062601049
60H082_1	6.0	93	57	1/20	5902062601056
60H086_1	8.0	117	75	1/20	5902062601063
60H090_1	10.0	133	87	1/20	5902062601070



## WIERTŁO DO METALU

Metal drills / Metallbohrer / Свёрла по металлу / Свёрла по металлу / Fémfúró / Burghie pentru metale / Vrtáky do kovu / Vrtáky do kovu / Svedri za kovino / Gražtai metalui / Urbis metálam / Metallipuur / Свёрла за метал / Svrđla za metal / Burgija za metal / Τρυπάνια μετάλλου / Brocas para metal / Punta per metallo / Brocas p. metal / Forêts à métal / Boor voor metaal

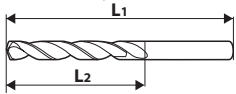

Ref.	Ø [mm]	L1	L2	☒	EAN
60H772	4.0	119	78	200/1800	5902062607720
60H774	5.0	132	87	100/700	5902062607744
60H776	6.0	139	91	100/700	5902062607768
60H778	8.0	165	109	50/400	5902062607782
60H780	10.0	184	121	50/300	5902062607805



## WIERTŁA DO METALU

Metal drills / Metallbohrer / Свёрла по металлу / Свёрла по металлу / Fémfúró / Burghie pentru metale / Vrtáky do kovu / Vrtáky do kovu / Svedri za kovino / Gražtai metalui / Urbis metálam / Metallipuur / Свёрла за метал / Svrđla za metal / Burgija za metal / Τρυπάνια μετάλλου / Brocas para metal / Punta per metallo / Brocas p. metal / Forêts à métal / Boor voor metaal



x5

HSS



DIN 338



Ref.	Ø [mm]	☒	EAN
60H000	4, 5, 6, 8, 10	0/10	5902062600004

## WIERTŁA DO METALU

Metal drills / Metallbohrer / Свёрла по металлу / Свёрла по металлу / Fémfúró / Burghie pentru metale / Vrtáky do kovu / Vrtáky do kovu / Svedri za kovino / Gražtai metalui / Urbis metálam / Metallipuur / Свёрла за метал / Svrđla za metal / Burgija za metal / Τρυπάνια μετάλλου / Brocas para metal / Punta per metallo / Brocas p. metal / Forêts à métal / Boor voor metaal

x19

HSS

TiN



DIN 338



Ref.	Ø [mm]	☒	EAN
60H739	1,0 - 10,0	0/30	5902062060907

## WIERTŁO DO BETONU

Concrete drills / Betonbohrer / Свёрла по бетону / Свёрла по бетону / Betonfúró / Burghie pentru beton / Vrtáky do betonu / Vrtáky do betonu / Svedri za beton / Gražtai betonui / Betona urbji / Betoonipuur / Свёрла за бетон / Svrđlo za beton / Burgije za beton / Τρυπάνια μπετόν / Brocas para hormigón / Punta per calcestruzzo / Brocas p. Betão / Forêts pour béton / Boor voor beton

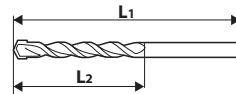

Ref.	Ø [mm]	L1	L2	☒	EAN
60H172	4	75	40	0/1	5902062601728
60H174	6	100	60	0/1	5902062601742
60H176	8	120	80	0/1	5902062601766
60H178	10	120	80	0/1	5902062601780
60H180	12	150	85	0/1	5902062601803
60H182	14	150	85	0/1	5902062601827
60H190	6	250	135	0/1	5902062601902
60H192	8	250	135	0/1	5902062601926
60H194	10	250	135	0/1	5902062601940
60H196	12	250	135	0/1	5902062601964
60H198	14	250	135	0/1	5902062601988

## WIERTŁA DO BETONU

Concrete drills / Betonbohrer / Свёрла по бетону / Свёрла по бетону / Betonfúró / Burghie pentru beton / Vrtáky do betonu / Vrtáky do betonu / Svedri za beton / Gražtai betonui / Betona urbji / Betoonipuur / Свёрла за бетон / Svrđlo za beton / Burgije za beton / Τρυπάνια μπετόν / Brocas para hormigón / Punta per calcestruzzo / Brocas p. Betão / Forêts pour béton / Boor voor beton

x5



Ref.	Ø [mm]	☒	EAN
60H300	4, 5, 6, 8, 10	0/100	5902062603005

VERTO

## OTWORNICA

Compass saw / Lachsäge / Ножовка / Фреза / Körkivágó / Ferästråu pentru gäuri / Dërovka / Dierovacia pila / Luknjaica / Vienarankis pjūklas / Rokzāģis / Augusaag / Тесен тριων / Nareznica / Ručna testera za pravljenje otvora / Πριόνι / Sierra de corona / Segá a tazza / Serra para recorte / Scie à guichet / Gatenknipper

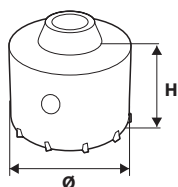

Ref.	Ø [mm]	H [mm]	☒	EAN
60H265	65	50	0/30	5902062506504
60H280	80	50	0/30	5902062508003

## ADAPTER DO OTWORNIC DO BETONU

Hole cutter adaptor / Adapter für Betonstichsägen / Переходник для коронок по бетону / Адаптер до вижуржальника по бетону / Adapter fürókalapácsos / Adaptor p/u sfredelirea sondelor / Adapter do dërovek na beton / Stopka SDS + vrták / Adapter SDS / Adapteris karünai, betonui grežti / Adapters krapurbim / Augulóikuri adapter / SDS Αδαντορ / SDS adapter / SDS adapter / Αντάτορας για ποτρωκόρωνα για μπετόν / Adaptador de sierras de corona perforadoras de hormigón / Adattatore per seghe da traforo per calcestruzzo / Adaptador p. serras para recorte p. betão / Adaptateur de scie à guichet pour béton / Adaptor voor betonknipper

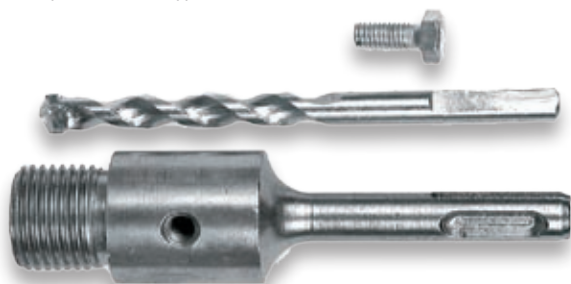

Ref.	typ	☒	EAN
60H210	SDS plus	0/100	5902062506559
60H214	SDS Max	0/60	5902062602145

## ADAPTER DO OTWORNIC DO BETONU

Hole cutter adaptor / Adapter für Betonstichsägen / Переходник для коронок по бетону / Адаптер до вижуржальника по бетону / Adapter fürókalapácsos / Adaptor p/u sfredelirea sondelor / Adapter do dërovek na beton / Stopka SDS + vrták / Adapter SDS / Adapteris karünai, betonui grežti / Adapters krapurbim / Augulóikuri adapter / SDS Αδαντορ / SDS adapter / SDS adapter / Αντάτορας για ποτρωκόρωνα για μπετόν / Adaptador de sierras de corona perforadoras de hormigón / Adattatore per seghe da traforo per calcestruzzo / Adaptador p. serras para recorte p. betão / Adaptateur de scie à guichet pour béton / Adaptor voor betonknipper

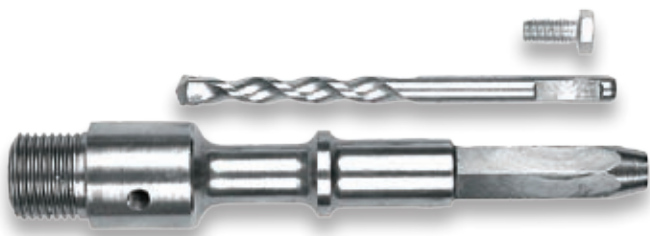

Ref.	☒	EAN
60H212	0/60	5902062508058

## WIERTŁO DO BETONU

Masonry drill / Betonbohrer / Свёрло по бетону / Свърло по бетону / Betonfúró / Sfredel beton / Vrták do betonu / Vrták do betónu / Sveder za beton / Grązias betonui / Urbis betonam / Müüripuur / Burgija za beton / Τριώνι για διάτρηση μπετόν / Broca para hormigón / Punta da trapano per calcestruzzo / Broca p. Betão / Foret pour béton / Boor voor beton

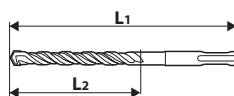

Ref.	Ø [mm]	L1	L2	☒	EAN
60H620	4	110	50	25/300	5902062606204
60H621	5	110	50	25/300	5902062606211
60H622	6	110	50	25/300	5902062606228
60H623	8	110	50	25/300	5902062606235
60H624	10	110	50	25/300	5902062606242
60H625	12	110	50	25/300	5902062606259
60H626	5	160	100	25/200	5902062606266
60H627	6	160	100	25/200	5902062606273
60H628	8	160	100	25/200	5902062606280
60H629	10	160	100	25/200	5902062606297
60H630	12	160	100	25/200	5902062606303
60H631	14	160	100	25/150	5902062606310
60H632	16	160	100	25/150	5902062606327
60H633	6	210	150	25/150	5902062606334
60H634	8	210	150	25/150	5902062606341
60H635	10	210	150	25/150	5902062606358
60H636	12	210	150	25/150	5902062606365
60H637	14	210	150	25/100	5902062606372
60H638	6	260	200	25/100	5902062606389
60H639	8	260	200	0/100	5902062606396
60H640	10	260	200	25/100	5902062606402
60H641	12	260	200	25/100	5902062606419
60H642	14	260	200	25/50	5902062606426
60H643	16	260	200	25/50	5902062606433
60H644	18	260	200	25/50	5902062606440
60H645	16	310	250	0/50	5902062606457
60H646	18	310	250	25/50	5902062606464
60H647	10	350	290	25/100	5902062606471
60H648	14	350	290	25/50	5902062606488
60H649	10	400	340	25/100	5902062606495
60H650	12	400	340	25/100	5902062606501
60H651	14	400	340	25/50	5902062606518
60H652	16	400	340	25/50	5902062606525
60H653	12	450	390	25/50	5902062606532
60H654	14	450	390	0/25	5902062606549
60H655	10	600	540	25/50	5902062606556
60H656	12	600	540	25/50	5902062606563
60H657	14	600	540	0/25	5902062606570
60H658	16	600	540	0/25	5902062606587
60H659	18	600	540	0/25	5902062606594
60H660	20	600	540	0/10	5902062606600
60H661	24	600	540	0/10	5902062606617
60H662	20	800	740	0/10	5902062606624
60H663	24	800	740	0/10	5902062606631

## WIERTŁO DO BETONU

Masonry drill / Betonbohrer / Свёрло по бетону / Свърло по бетону / Betonfúró / Sfredel beton / Vrták do betonu / Vrták do betónu / Sveder za beton / Grązias betonui / Urbis betonam / Müüripuur / Burgija za beton / Τριώνι για διάτρηση μπετόν / Broca para hormigón / Punta da trapano per calcestruzzo / Broca p. Betão / Foret pour béton / Boor voor beton

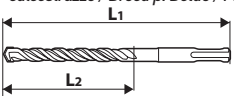

Ref.	Ø [mm]	L1	L2	☒	EAN
60H704	16	260	120	0/42	5902062607041
60H709	16	400	260	0/37	5902062607089
60H710	16	600	460	0/30	5902062607102
60H714	18	310	170	0/50	5902062607140
60H720	18	600	460	0/30	5902062607188
60H721	20	600	460	0/22	5902062607201
60H722	20	800	660	0/16	5902062607225
60H724	24	600	460	0/17	5902062607249
60H726	24	800	660	0/12	5902062607263
60H728	24	1000	860	0/10	5902062607287
60H732	28	600	460	0/13	5902062607324
60H734	28	800	660	0/10	5902062607348
60H738	28	1200	1060	0/6	5902062607386
60H740	32	600	460	0/10	5902062607409
60H742	32	800	660	0/6	5902062607423
60H744	32	1000	860	0/6	5902062607447
60H746	32	1200	1060	0/5	5902062607461

## WIERTŁO DO BETONU

Concrete drills / Betonbohrer / Сверла по бетону / Сврџла по бетону / Betonfúró / Burghie pentru beton / Vrtáky do betonu / Vrtáky do betónu / Svedri za beton / Gražtali betonui / Betona urbij / Betonipuur / Сврџла за бетон / Svrđlo za beton / Burgije za beton / Τρυπάνια μπετόν / Brocas para hormigón / Punte per calcestruzzo / Brocas p. Betão / Forêts pour béton / Boor voor beton

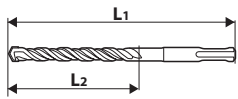

## DŁUTA

Chisel / Beitel / Долово / Зубило / Laposvéső / Daltă / Dláto / Sekáč plochý SDSplus / Sekáč / Kaltas / Kalts / Peitel / Секач SDS Plus 1 / Sjekac / Sekac / Σμίλη / Formón / Scalpello / Raspador / Ciseau / Beitels



Ref.	Ø [mm]	L1	L2	☒	EAN
60H516	4	110	50	0/300	5902062605160
60H518	5	110	50	0/200	5902062605184
60H520	5	160	100	0/200	5902062605207
60H522	6	110	50	10/300	5902062605221
60H524	6	160	100	0/200	5902062605245
60H526	6	210	150	0/150	5902062605269
60H528	6	260	200	0/200	5902062605283
60H532	8	160	100	0/200	5902062605320
60H534	8	210	150	0/150	5902062605344
60H536	8	260	200	0/200	5902062605368
60H540	10	160	100	0/200	5902062605405
60H542	10	210	150	0/150	5902062605429
60H544	10	260	200	0/100	5902062605443
60H546	10	350	290	0/100	5902062605467
60H548	10	400	340	0/120	5902062605481
60H550	10	600	540	0/100	5902062605504
60H554	12	160	100	0/200	5902062605542
60H556	12	210	150	0/200	5902062605566
60H558	12	260	200	0/200	5902062605580
60H562	12	400	340	0/100	5902062605627
60H564	12	450	390	0/100	5902062605641
60H566	12	600	540	0/50	5902062605665
60H570	14	210	150	0/180	5902062605702
60H572	14	260	200	0/100	5902062605726
60H576	14	350	290	0/90	5902062605764
60H578	14	400	340	0/80	5902062605788
60H580	14	450	390	0/60	5902062605801
60H582	14	600	540	0/25	5902062605825
60H588	16	260	200	0/110	5902062605887
60H590	16	310	250	0/90	5902062605900
60H592	16	400	340	0/50	5902062605924
60H594	16	600	540	0/25	5902062605948
60H596	18	260	200	10/80	5902062605962
60H598	18	310	250	0/50	5902062605986
60H602	18	600	540	0/30	5902062606020
60H604	20	600	540	0/26	5902062606044
60H606	20	800	740	0/20	5902062606068
60H608	24	600	540	0/20	5902062606082
60H610	24	800	740	0/10	5902062606105

## DŁUTO

Chisel / Beitel / Долово / Зубило / Laposvéső / Daltă / Dláto / Sekáč plochý SDSplus / Sekáč / Kaltas / Kalts / Peitel / Секач SDS Plus 1 / Sjekac / Sekac / Σμίλη / Formón / Scalpello / Raspador / Ciseau / Beitel

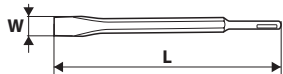

Ref.	L [mm]	☒	EAN
60H240	250	0/20	5902062515049

## FREZY WIDIOWE

Rotary bit set / Hartmetallfräser / Фрезы профильные / Фрези профилни, набір / Fenékfúró készlet / Set de dălti rotative / Vidiové kotouče / Súprava homých fréz / Gamitura rezkal / Frezos / Frēzes kokam / Pöördotsikute komplekt / Фрези за дърво / Profilni frezeri na drsci / Profilisani frezeri na drsci / Περιστροφικές φρέζες / Broca fresadora de widia / Frese di vidia / Fresas / Fraises widia / Roteerfrees

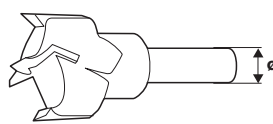

x12

HM



Ref.	Ø [mm]	☒	EAN
60H008	6	0/20	5902062070180
60H010	8	0/20	5902062070197

## WIERTŁO DO KONFIRMATÓW

Special wood drill / Konfirmatbohrer / Сверло для конфирматов / Сврџло до конфирмату / Sülylesztőfúró / Burghiu special pentru lemn / Vrták na konfirmáty / Vrták na konfirmáty / Specialni sveder za les / Specialus medžio gražtas / Koka urbis iedobēm / Spetsiaalne puidudrell / Бурзя спецауапа / Svrđlo za konfirmate / Burgija za beton / Ειδικό τρυπάνι για ξύλο / Broca para tornillos conifirmat / Trapano speciale / Broca especial / Foret à vis à bois / Boor voor speciaal hout

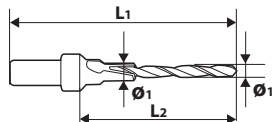

Ref.	Ø1 [mm]	Ø2 [mm]	L1 [mm]	L2 [mm]	☒	EAN
60H896	4	6	90	60	0/10	5902062608963
60H897	5	7	90	60	0/10	5902062608970

VERTO

## FREZ WIDIOWY

Counter-sink drill with carbid tipped blades / Widi-Fräser / Сверло-фреза / Сверло-фреза / Vidia marófej / Freza cu cap Vidia / Vidiová fréza / Vidiová fréza / Rezkalo vidia / Freza (dengta karbidu) / Fréze / Kahvelfrees / Τετράοιπληθη φρέζα / Vidija frez / Frezer od vidija-metala / Τριπλάνα σκληρού μετάλλου / Broca fresadora de vidia / Frees met hardmetalen dop

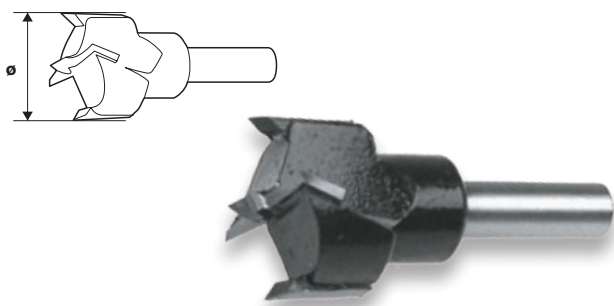

Ref.	Ø [mm]	☒	EAN
60H825	25	0/250	5902062526250
60H832	32	0/250	5902062526328
60H835	35	0/250	5902062526359

## OTWORNICA

Compass saw / Lochsäge / Ножовна / Фреза / Kórkivágó / Ferásträu pentru găuri / Dėrovka / Dierovacia pila / Luknjarića / Vienarankis pjūklas / Rokzāģis / Augusaag / Тесен тпион / Nareznica / Ručna testera za pravljenje otvora / Πριόνι / Sierra de corona / Seghe a tazza / Serra para recorte / Scie à guichet / Gatenskippers

ELEKTRONARZĘDZIA / VERTO

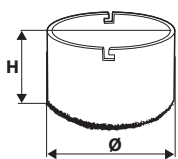

Ref.	Ø [mm]	H [mm]	☒	EAN
60H902	33	55	0/10	5902062609021
60H904	43	55	0/10	5902062609045
60H906	53	55	0/10	5902062609069
60H908	67	55	0/10	5902062609083
60H910	73	55	0/10	5902062609106
60H912	83	55	0/10	5902062609120

## TARCZA DO OTWORNIC

Blades for compass saw / Scheibe für Lochsägen / Диск для ножовок / Диск для фрез / Tártsa kórkivágóhoz / Disc pentru maşini de găurit / Κοτούς pro dėrovky / Kotuč dierovacej pily / Plošča za luknjarića / Diskas vienarankiam pjūklui / Griežņu disks / Augusae ketas / Диск за тесни тпиони / Ploča za nareznice / Ploča za otvore / Δίσκος για λίμες / Disco de corte para sierras de corona / Flangia di serraggio per seghe a tazza / Disco para Serras para recorte / Disque de scie à guichet / Schijf voor gatenskippers



Ref.	☒	EAN
60H914	0/10	5902062609144

## WIERTŁO PILOTUJĄCE

Pilot drill / Pilotbohrer / Сверло направляющее / Свердло направляющее / Kőzpontosító fúró / Burghiu pilot / Vodici vrták / Vodiaci vrták / Pilotni sveder / Centruojantis gražtas / Urbja vadikla / Pilotpuur / Направляющее свердло / Svrdla za predotvore / Pilot burgija / Τριπλάνα οδηγός / Broca centradora / Punta pilota / Broca de pilotagem / Foret de pilotage / Pilotboor



Ref.	☒	EAN
60H916	0/10	5902062609168

## OTWORNICE

Compass saw / Lochsäge / Ножовна / Фреза / Kórkivágó / Ferásträu pentru găuri / Dėrovka / Dierovacia pila / Luknjarića / Vienarankis pjūklas / Rokzāģis / Augusaag / Тесен тпион / Nareznica / Ručna testera za pravljenje otvora / Πριόνι / Sierra de corona / Seghe a tazza / Serra para recorte / Scie à guichet / Gatenskippers

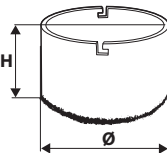

Ref.	Ø [mm]	H [mm]	☒	EAN
60H900	32 - 83	55	1/6	5902062609007

## OTWORNICE

Compass saw / Lochsäge / Ножовна / Фреза / Kórkivágó / Ferásträu pentru găuri / Dėrovka / Dierovacia pila / Luknjarića / Vienarankis pjūklas / Rokzāģis / Augusaag / Тесен тпион / Nareznica / Ručna testera za pravljenje otvora / Πριόνι / Sierra de corona / Seghe a tazza / Serra para recorte / Scie à guichet / Gatenskippers

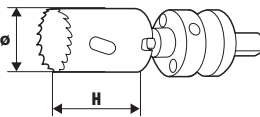

x7



Ref.	Ø [mm]	H [mm]	☒	EAN
60H964	38, 44, 51, 57, 64	38	0/10	5902062567253
60H968	19, 29, 33, 51, 68	38	0/10	5902062567307

## OTWORNICE

Compass saw / Lochsäge / Ножевка / Фреза / Körkivágó / Ferästräu pentru găuri / Dërovka / Dierovacia pila / Luknjačica / Venarankis pjūklas / Rokzāģis / Augusaag / Тесен трион / Nareznica / Ručna testera za pravljenje otvora / Πριότι / Sierra de corona / Seghe a tazza / Serra para recorte / Scie à guichet / Gatenknippers



Ref.	Ø [mm]	H [mm]	⊠	EAN
60H959	60 - 90	30	6/30	5902062071118

## TARČA TNAČA

Cutting disc / Schneidescheibe / Диск пильный / Диск різальний / Vágótárcsa / Disc tăietor / Pilový kotouč / Pilový kotúč / Rezinna plošča / Pjovimo diskas / Žāga disks / Lōikeketas / Режущий диск / Rezna ploča / Ploče za sečenje / Δίσκος κοπής / Disco de corte / Mola da taglio / Disco cortante / Disque de coupage / Snijpschijf



Ref.	Ø1 [mm]	Ø2 [mm]	W [mm]	TYP	⊠	EAN
61H401	115	22,2	1,5	41 A46-T-BF	0/25	5902062614018
61H402	125	22,2	1,5	41 A46-T-BF	0/25	5902062614025
61H404	115	22,2	1,0	41 A60-T-BF	0/25	5902062614049
61H405	125	22,2	1,0	41 A60-T-BF	0/25	5902062614056

## TARČA TNAČA

Cutting disc / Schneidescheibe / Диск пильный / Диск різальний / Vágótárcsa / Disc tăietor / Pilový kotouč / Pilový kotúč / Rezinna plošča / Pjovimo diskas / Žāga disks / Lōikeketas / Режущий диск / Rezna ploča / Ploče za sečenje / Δίσκος κοπής / Disco de corte / Mola da taglio / Disco cortante / Disque de coupage / Snijpschijf



Ref.	Ø1 [mm]	Ø2 [mm]	W [mm]	TYP	⊠	EAN
61H530	115	22,2	1,5	41 A46-T-BF	100/400	5902062615305
61H532	125	22,2	1,5	41 A46-T-BF	100/400	5902062615329
61H534	180	22,2	1,6	41 A46-T-BF	50/200	5902062615343
61H536	230	22,2	2,0	41 A46-T-BF	50/100	5902062615367

## TARČA SZLIFIERSKA

Grinding disc / Schleifscheibe / Круг шлифовальный / Диск шлифовальный / Köszörőkörong / Inel de șlefuire / Leštící kotouč / Kotúč na stolovú brúsku / Brusilna plošča / Šlifavimo diskas / Sljapdiskas / Lihvimisketas / Диск за шмиргел / Brusna ploča / Brusna ploča / Δίσκος λείανσης / Disco para amoladora de banco / Disco per rettificatrice da banco / Disco p. esmerilhar metal / Meule abrasive / Slijpschijf



Ref.	Ø1 [mm]	Ø2 [mm]	W [mm]	TYP	⊠	EAN
61H455	115	22,2	6,0	27 A24-R-BF	1/120	5902062614551
61H465	125	22,2	6,0	27 A24-R-BF	1/120	5902062614650

## TARČA TNAČA

Cutting disc / Schneidescheibe / Диск пильный / Диск різальний / Vágótárcsa / Disc tăietor / Pilový kotouč / Pilový kotúč / Rezinna plošča / Pjovimo diskas / Žāga disks / Lōikeketas / Режущий диск / Rezna ploča / Ploče za sečenje / Δίσκος κοπής / Disco de corte / Mola da taglio / Disco cortante / Disque de coupage / Snijpschijf

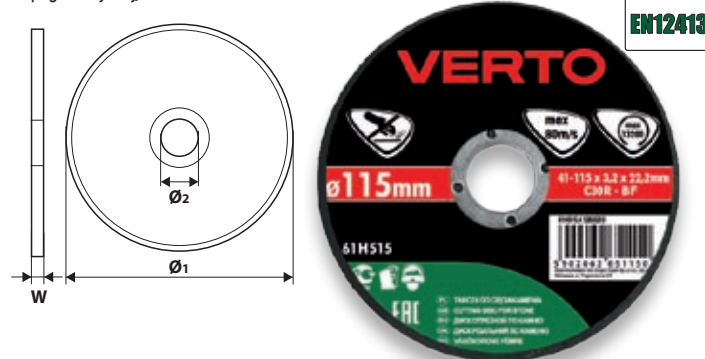

Ref.	Ø1 [mm]	Ø2 [mm]	W [mm]	TYP	⊠	EAN
61H515	115	22,2	3,2	41 C30-R-BF	0/25	5902062651150
61H525	125	22,2	3,2	42 C30-R-BF	0/25	5902062651259
61H523	230	22,2	3,2	41 C30-R-BF	0/15	5902062652300

## TARČA DIAMENTOWA

Diamond disc / Diamantscheibe / Диск алмазный / Диск алмазний / Gyémánt-vágótárcsa / Disc de diamant / Diamantový kotouč / Diamantový kotúč / Diamantna plošča / Deimantinis diskas / Dimanta / griezējdiskas / Teemantketas / Диск диамантен / Dijamantna rezna ploča / Dijamantski disk / Διαμαντένια δίσκοι κοπής / Disco de corte de diamante / Disco di diamante / Disco de diamante / Disque diamanté / Diamantschijf

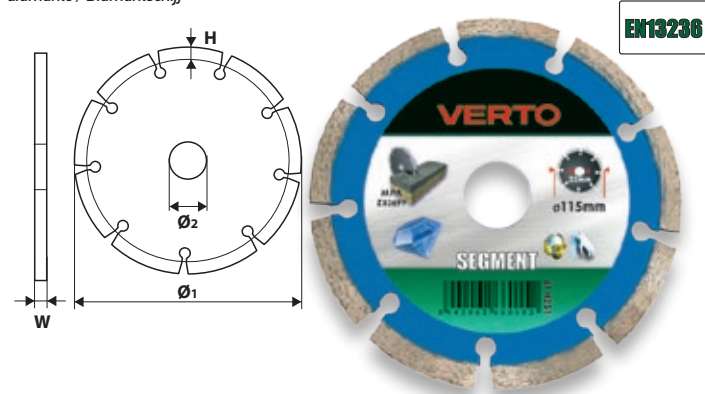

Ref.	Ø1 [mm]	Ø2 [mm]	W [mm]	H [mm]	⊠	EAN
61H2S1	115	22,2	2,0	7	10/100	5902062660152
61H2S5	125	22,2	2,0	7	10/100	5902062660251
61H2S8	180	22,2	2,0	7	10/50	5902062660183
61H2S9	230	22,2	2,0	7	10/50	5902062660237

# VERTO



## TARCA DIAMENTOWA

Diamond disc / Diamantscheibe / Диск алмазний / Диск алмазний / Gyémánt-vágótárcsa / Disc de diamant / Diamantový kotouč / Diamantový kotuč / Diamantna plošča / Deimantinis diskas / Dimanta griežējdisks / Teemantketas / Диск диамантен / Dijamantna rezna ploča / Dijamantski disk / Διαμαντένιο δίσκο κοπής / Disco de corte de diamante / Disco di diamante / Disco de diamante / Disque diamanté / Diamantschijf

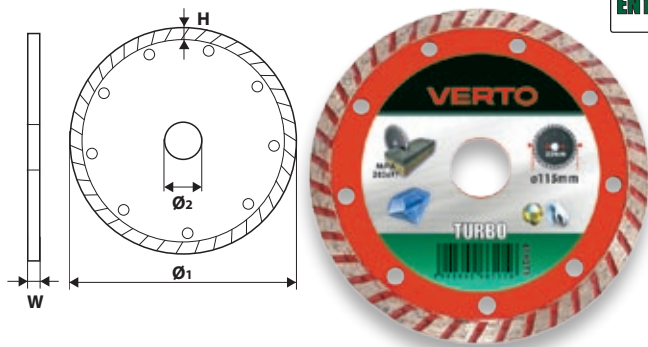

EN13236

Ref.	Ø1 [mm]	Ø2 [mm]	W [mm]	H [mm]	☒	EAN
61H2T1	115	22,2	2,0	7	10/100	5902062662156
61H2T5	125	22,2	2,0	7	10/100	5902062662255
61H2T8	180	22,2	2,0	7	10/50	5902062662187
61H2T9	230	22,2	2,0	7	10/50	5902062662231

## TARCA DIAMENTOWA

Diamond disc / Diamantscheibe / Диск алмазний / Диск алмазний / Gyémánt-vágótárcsa / Disc de diamant / Diamantový kotouč / Diamantový kotuč / Diamantna plošča / Deimantinis diskas / Dimanta griežējdisks / Teemantketas / Диск диамантен / Dijamantna rezna ploča / Dijamantski disk / Διαμαντένιο δίσκο κοπής / Disco de corte de diamante / Disco di diamante / Disco de diamante / Disque diamanté / Diamantschijf

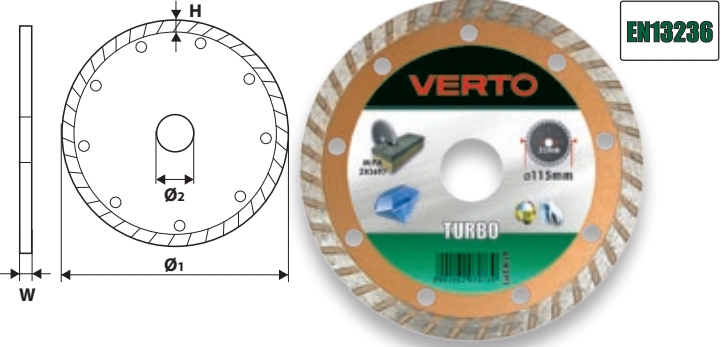

EN13236

Ref.	Ø1 [mm]	Ø2 [mm]	W [mm]	H [mm]	☒	EAN
61H3P1	115	22,2	2,0	7	10/100	5902062070739
61H3P5	125	22,2	2,0	7	10/100	5902062070746
61H3P8	180	22,2	2,0	7	10/50	5902062070753
61H3P9	230	22,2	2,0	7	10/50	5902062070760

## TARCA DIAMENTOWA

Diamond disc / Diamantscheibe / Диск алмазний / Диск алмазний / Gyémánt-vágótárcsa / Disc de diamant / Diamantový kotouč / Diamantový kotuč / Diamantna plošča / Deimantinis diskas / Dimanta griežējdisks / Teemantketas / Диск диамантен / Dijamantna rezna ploča / Dijamantski disk / Διαμαντένιο δίσκο κοπής / Disco de corte de diamante / Disco di diamante / Disco de diamante / Disque diamanté / Diamantschijf

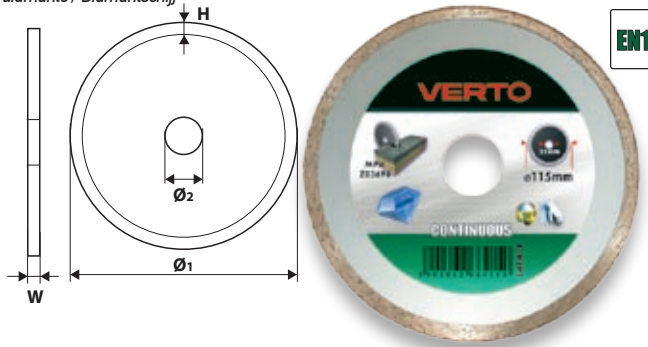

EN13236

Ref.	Ø1 [mm]	Ø2 [mm]	W [mm]	H [mm]	☒	EAN
61H2P1	115	22,2	2,0	6	10/100	5902062664150
61H2P5	125	22,2	2,0	6	10/100	5902062664259
61H2P8	180	22,2	2,0	6	10/50	5902062664181
61H2P9	230	22,2	2,0	6	10/50	5902062664235

## TARCA DIAMENTOWA

Diamond disc / Diamantscheibe / Диск алмазний / Диск алмазний / Gyémánt-vágótárcsa / Disc de diamant / Diamantový kotouč / Diamantový kotuč / Diamantna plošča / Deimantinis diskas / Dimanta griežējdisks / Teemantketas / Диск диамантен / Dijamantna rezna ploča / Dijamantski disk / Διαμαντένιο δίσκο κοπής / Disco de corte de diamante / Disco di diamante / Disco de diamante / Disque diamanté / Diamantschijf

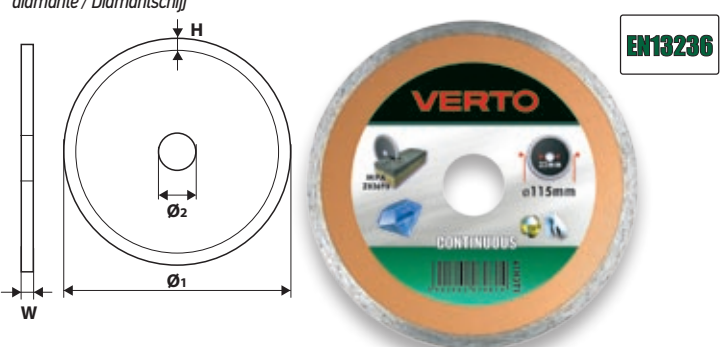

EN13236

Ref.	Ø1 [mm]	Ø2 [mm]	W [mm]	H [mm]	☒	EAN
61H3T1	115	22,2	2,0	7	10/100	5902062070814
61H3T5	125	22,2	2,0	7	10/100	5902062070821
61H3T8	180	22,2	2,0	7	10/50	5902062070838
61H3T9	230	22,2	2,0	7	10/50	5902062070845

## TARCA DIAMENTOWA

Diamond disc / Diamantscheibe / Диск алмазний / Диск алмазний / Gyémánt-vágótárcsa / Disc de diamant / Diamantový kotouč / Diamantový kotuč / Diamantna plošča / Deimantinis diskas / Dimanta griežējdisks / Teemantketas / Диск диамантен / Dijamantna rezna ploča / Dijamantski disk / Διαμαντένιο δίσκο κοπής / Disco de corte de diamante / Disco di diamante / Disco de diamante / Disque diamanté / Diamantschijf

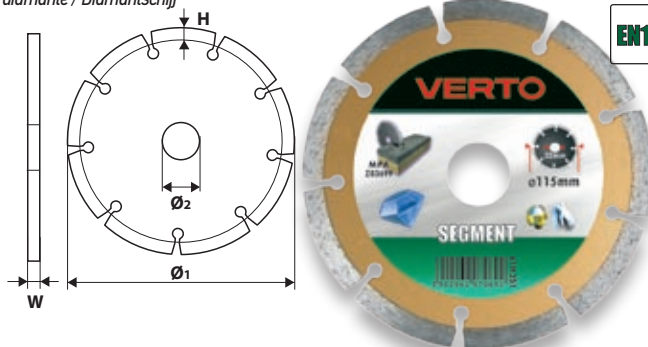

EN13236

Ref.	Ø1 [mm]	Ø2 [mm]	W [mm]	H [mm]	☒	EAN
61H3S1	115	22,2	2,0	7	10/100	5902062070692
61H3S5	125	22,2	2,0	7	10/100	5902062070708
61H3S8	180	22,2	2,0	7	10/50	5902062070715
61H3S9	230	22,2	2,0	7	10/50	5902062070722

## TARCA DIAMENTOWA

Diamond disc / Diamantscheibe / Диск алмазний / Диск алмазний / Gyémánt-vágótárcsa / Disc de diamant / Diamantový kotouč / Diamantový kotuč / Diamantna plošča / Deimantinis diskas / Dimanta griežējdisks / Teemantketas / Диск диамантен / Dijamantna rezna ploča / Dijamantski disk / Διαμαντένιο δίσκο κοπής / Disco de corte de diamante / Disco di diamante / Disco de diamante / Disque diamanté / Diamantschijf

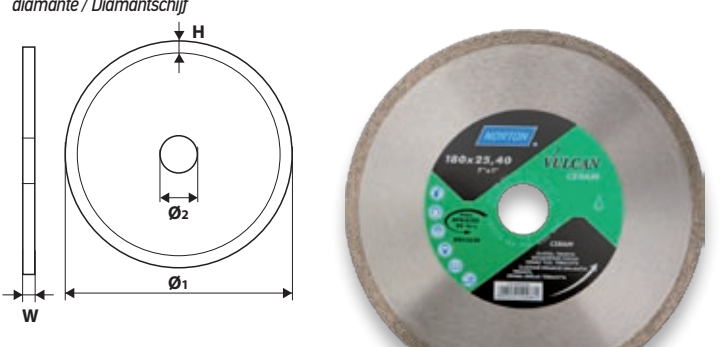

NORTON

Ref.	Ø1 [mm]	Ø2 [mm]	W [mm]	H [mm]	☒	EAN
70184625182	180	25,4	2,0	7	10/100	5900442102681
70184625097	250	25,4	2,0	7	10/100	5450248344032

## TARČA DO PILARKI

Circular saw blade / Sägeblatt / Диск пильный / Диск пильный до пилки циркулярной / Körfűrészlap / Lamă circulară p/u ferăstrău / Pilový kotouč / Pilový kotúč / List za krožno žago / Pjovimo diskas pjūklui / Žağa rıpa / Kreissaeketas / Диск за циркуляр / Kružna Pila / List kružne testere / Δίσκος κοπής διακοπύου / Disco de corte para sierra circular / Disco per segatrice / Disco p. disco de limar / Disque à scie rotative / Schijf voor slijpmachine

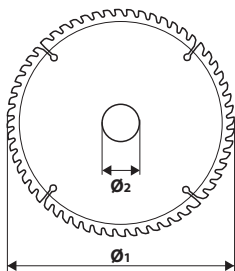

Ref.	Ø1 [mm]	Ø2 [mm]	↘ xN	☒	EAN
61H190	200	30	60	0/50	5902062611901
61H194	215	30	60	0/50	5902062611949

## TARČA DO PILARKI

Circular saw blade / Sägeblatt / Диск пильный / Диск пильный до пилки циркулярной / Körfűrészlap / Lamă circulară p/u ferăstrău / Pilový kotouč / Pilový kotúč / List za krožno žago / Pjovimo diskas pjūklui / Žağa rıpa / Kreissaeketas / Диск за циркуляр / Kružna Pila / List kružne testere / Δίσκος κοπής διακοπύου / Disco de corte para sierra circular / Disco per segatrice / Disco p. disco de limar / Disque à scie rotative / Schijf voor slijpmachine

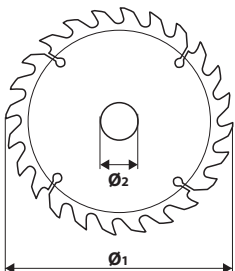

Ref.	↘ xN	Ø1 [mm]	Ø2 [mm]	redukcja [mm]	☒	EAN
61H114	24	140			0/50	5902062631428
61H116	18	160			0/50	5902062631619
61H118	24	160			0/50	5902062631626
61H120	30	160			0/50	5902062631633
61H121	24	185			0/50	5902062611215
61H123	36	185			0/50	5902062611239
61H125	48	185			0/50	5902062611253
61H122	24	190			0/50	5902062631923
61H124	40	190			0/50	5902062631947
61H126	52	190			0/50	5902062631954
61H128	24	200	30	25,4	0/50	5902062632029
61H130	40	200	30	20	0/50	5902062632043
61H132	60	200	30	16	0/50	5902062632067
61H134	40	250			0/25	5902062632548
61H136	40	300			0/25	5902062633040
61H138	60	300			0/25	5902062633064
61H140	40	315			0/25	5902062633149
61H142	40	350			0/10	5902062633545
61H144	60	350			0/10	5902062633569
61H146	40	400			0/5	5902062634047
61H148	60	400			0/5	5902062634061
61H150	60	450			0/5	5902062634566

## TARČA ŁAŃCUCHOWA

Chain circular blade / Kettenscheibe / Диск цепной / Диск ланцюговий по дереву / Láncos körfűrészlap / Čuť circular p/u ferăstrău cu lanț / Retězové kolo / Retazový kotúč na drevo / Krožna žaga z verigo / Grandininis pjovimo diskas / Kėži rıpa / Saekett (ringikujulised hambad) / Диск за рязане / Disk sa lancem za sjećenje drveta / Disk sa lancem za secenje / Δίσκος κοπής αλυσοπύου / Disco con cadena / Disco per segatrice / Disco de corrente / Disque à chaîne / Kettenschijf

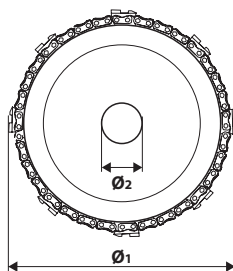

Ref.	Ø1 [mm]	Ø2 [mm]	☒	EAN
61H196	115	22,2	0/1	5902062611963
61H197	125	22,2	0/1	5902062611970
61H199	230	22,2	0/1	5902062611994

## TARČA SZLIFIERSKA

Grinding disc / Schleifscheibe / Круг шлифовальный / Диск шліфувальний / Köszörőkör / Inel de șlefuire / Leštící kotouč / Kotúč na stolovú brúsku / Brusilna plošča / Šlifavimo diskas / Šlipdiskas / Lihvimisketas / Диск за шмпурел / Brusna ploča / Brusna ploca / Δίσκος λείανσης / Disco para amoladora de banco / Disco per rettificatrice da banco / Disco p. esmerilhar metal / Meule abrasive / Slijpschijf

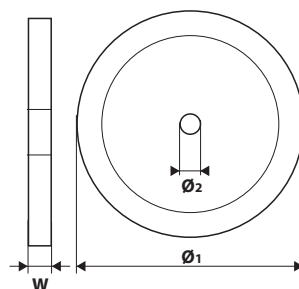

x2

Ref.	Ø1 [mm]	Ø2 [mm]	W [mm]	redukcja [mm]	☒	EAN
61H603	125	20	20	12,7 16	0/10	5902062070777
61H605	150	20	20	12,7 16	0/10	5902062070784
61H607	200	20	20	12,7 16	0/10	5902062070791

## TARČA SZLIFIERSKA

NORTON

Grinding disc / Schleifscheibe / Круг шлифовальный / Диск шліфувальний / Köszörőkör / Inel de șlefuire / Leštící kotouč / Kotúč na stolovú brúsku / Brusilna plošča / Šlifavimo diskas / Šlipdiskas / Lihvimisketas / Диск за шмпурел / Brusna ploča / Brusna ploca / Δίσκος λείανσης / Disco para amoladora de banco / Disco per rettificatrice da banco / Disco p. esmerilhar metal / Meule abrasive / Slijpschijf

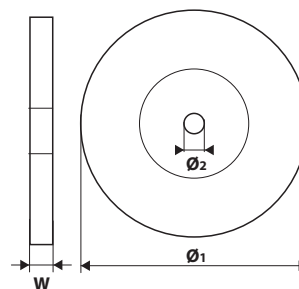

Ref.	Ø1 [mm]	Ø2 [mm]	W [mm]	K	☒	EAN
69210448990	200	20	40	80	0/10	5900442604260

# VERTO

## TARCA ELASTYCZNA

Elastic disc / Flexible Scheibe / Эластичный диск / Диск еластичний / Elastikus tárcsa / Disc elastic / Elastický kotouč / Elastický kotúč / Elastična plošča / Elastinis diskas / Elastīgais disks / Elastne kets / Эластичен диск / Elastična ploča / Elastična ploča / Ελαστικός δίσκος / Disco elástico / Disco elastico / Disco elástico / Disque flexible / Flexibele schijf

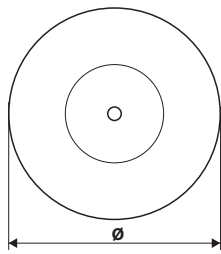

Ref.	Ø [mm]	info	☒	EAN
61H710	125	stała	0/10	5902062070159
61H720	125	uchyłna	0/10	5902062070166

## TARCA ELASTYCZNA

Elastic disc / Flexible Scheibe / Эластичный диск / Диск еластичний / Elastikus tárcsa / Disc elastic / Elastický kotouč / Elastický kotúč / Elastična plošča / Elastinis diskas / Elastīgais disks / Elastne kets / Эластичен диск / Elastična ploča / Elastična ploča / Ελαστικός δίσκος / Disco elástico / Disco elastico / Disco elástico / Disque flexible / Flexibele schijf

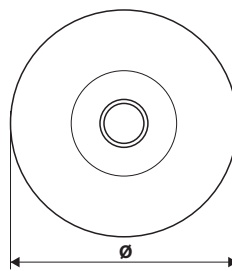

Ref.	Ø [mm]	☒	EAN
61H735	125	0/10	5902062617354

## TARCA ELASTYCZNA

Elastic disc / Flexible Scheibe / Эластичный диск / Диск еластичний / Elastikus tárcsa / Disc elastic / Elastický kotouč / Elastický kotúč / Elastična plošča / Elastinis diskas / Elastīgais disks / Elastne kets / Эластичен диск / Elastična ploča / Elastična ploča / Ελαστικός δίσκος / Disco elástico / Disco elastico / Disco elástico / Disque flexible / Flexibele schijf

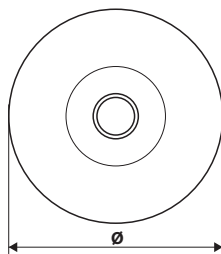

Ref.	Ø [mm]	☒	EAN
61H730	125	0/10	5902062070876

## RZEP SAMOPRZYLEPNY

Hook and loop fastener / Klettverschluss / Самоклеющаяся наклейка / Лупучка / Öntapadó tépőzár / Scai / Samolepící suchý zip / Suchý zips / Samolepilni velcro / Kibus šlifavimo tapas (vamalėša) / Pašlīmējoša uzlīme / Iselīmuv kinnītus / Самозалепяц се пенеу / Samolepljivi čičak / Samolepljivi čičak / Βέλκρο / Velcro / Velcro / Elemento autocollante / Adhésif Velcro / Velcrobond

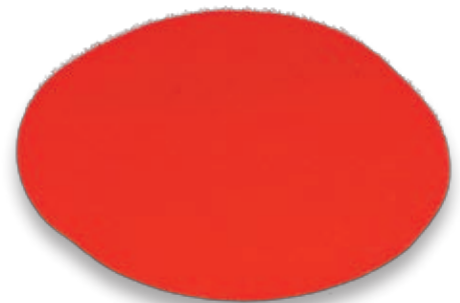
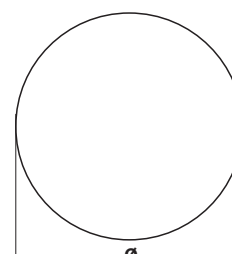

Ref.	Ø [mm]	☒	EAN
61H702	125	0/10	5902062617026
61H704	150	0/10	5902062617040

## TARCA ELASTYCZNA

Elastic disc / Flexible Scheibe / Эластичный диск / Диск еластичний / Elastikus tárcsa / Disc elastic / Elastický kotouč / Elastický kotúč / Elastična plošča / Elastinis diskas / Elastīgais disks / Elastne kets / Эластичен диск / Elastična ploča / Elastična ploča / Ελαστικός δίσκος / Disco elástico / Disco elastico / Disco elástico / Disque flexible / Flexibele schijf

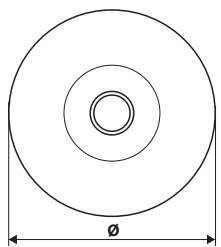

Ref.	Ø [mm]	☒	EAN
61H740	125	0/80	5902062617408

## FUTRO POLERSKIE

Polishing buff / Plierstoff / Шкурка полировочная / Хутряний полірувальний круг / Polírozó szűrte / Blană de lustruit / Leštící kožešina / Leštiači kotúč / Polirno krzno / Poliravimo kailis / Pulešanas audēkls / Poleerimiskarusnahk / Кожка за полиране / Krzno za poliranje / Krzno za poliranje / Γούνα στίλβωσης / Caperuzas de lana de oveja / Cuffia per lucidatura / Pele para polir / Fournure de polissage / Polijst buff

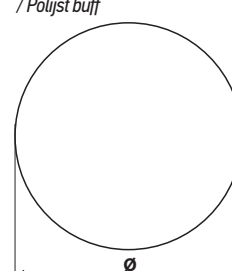

Ref.	Ø [mm]	☒	EAN
61H706	125	0/10	5902062617064
61H708	150	0/10	5902062617088

## GABKA POLERSKA

Polishing sponge / Polierschwamm / Губка полировальная / Губка полирувальна / Polirózó szivacs / Burete lustruitor / Leštící houba / Leštíaca špongia / Polirna goba / Poliravimo kempinė / Pulēšanas sūklis / Poleerimiskäsn / Полировочна гъба / Spužva za poliranje / Polerski sunder / Σπόγγος στίλβωσης / Esponja de pulido / Spugna per lucidatura / Esponja para polir / Mousse de polissage / Polijstpons

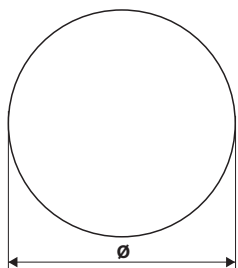

Ref.	Ø [mm]		EAN
61H709	125	0/10	5902062617095

## FILC POLERSKI

Polishing felt / Polierfilz / Фетр полировочный / Фільтр полірувальний / Polirkorong / Pislä slefuire / Leštící plst / Filcový disk / Filc za poliranje / Veltinis poliravimui / Filcis pulēšanai / Poleerimisvilt / Диск за полиране / Filc za poliranje / Filc za poliranje / Τάχα γυαλίματος / Filtro para pulir / Filtro per lucidatura / Feltro para poli / Feutre de polissage / Polijstvilt

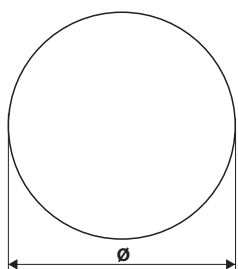

Ref.	Ø [mm]		EAN
61H700	125	5/150	5902062617002

## WŁÓKNINA ŚCIERNA

Abrasive cloth / Schleifstoff / Наждачное волокно / Волокно абразивне / Csiszolófilc / Tesäturű abrazív / Brusné rouno / Brúsná vlákna / Brusno vlakno / Slifavimo medžiaga / Slipēšanas audeklis / Lihvkiud / Абразивна тъкан / Brusna tkanina / Abrazivna tkanina / Υφασμα λείανσης / Tela de lijar / Tessuto abrasivo / Tecido abrasivo / Textile abrasif / Schuurtextiel

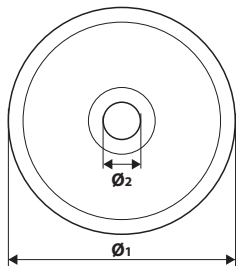

Ref.	Ø1 [mm]	Ø2 [mm]		EAN
61H930	125	22,2	0/10	5902062619303

## ŚCIERNICA LISTKOWA

Flap wheel / Blatt-Schleifscheibe / Листовой шлифовальный круг / Круг шлифовальный листковый / Lamellás csiszoló / Disc de rectificat / Brusný kotouč listkový / Brúsný lamelový tanier / Brus z lističi / Slifavimo lapeliai / Lokšņu slipēšanas riņķis / Lamell-lihvketas / Ламелен диск / Lepezasta brusna ploča / Kolut za brušenje / Τροχός λείανσης με πτερύγια / Abanico lijador / Spazzola lamellare / Disco abrasivo de folhas / Meule abrasive à lamelles / Schuurblad

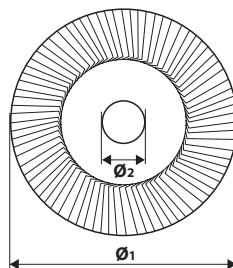

Ref.	Ø1 [mm]	Ø2 [mm]	gradacija		EAN
61H853	115	22,2	K36	10/100	5902062618535
61H854	115	22,2	K40	10/100	5902062618542
61H856	115	22,2	K60	10/100	5902062618566
61H858	115	22,2	K80	10/100	5902062618580
61H860	115	22,2	K100	10/100	5902062618603
61H862	115	22,2	K120	10/100	5902062618627
61H873	125	22,2	K36	10/100	5902062618733
61H874	125	22,2	K40	10/100	5902062618740
61H876	125	22,2	K60	10/100	5902062618764
61H878	125	22,2	K80	10/100	5902062618788
61H880	125	22,2	K100	10/100	5902062618801
61H882	125	22,2	K120	10/100	5902062618825

## PAS BEZKOŃCOWY

Sanding belt / Riemen endlos / Лента абразивная бесконечная / Стрічка наждачна безкінечна / Csiszolószalag / Bandă de slefuit / Pískový brusný pás / Brusný pás / Neskončni trak / Slifavimo juosta / Slīplenta / Lihvimislint / Brusni traka / Λειαντική ταινία / Banda lijadora / Cinghia ad anello / Cinto sem fim / Ceinture sans fin / Schuurbandslijper

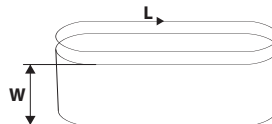

x31



Ref.	W x L [mm]	gradacija		EAN
63H614	75 x 457	K40	0/180	5902062211088
63H616	75 x 457	K60	0/180	5902062211095
63H618	75 x 457	K80	0/180	5902062211101
63H620	75 x 457	K100	0/180	5902062211118
63H622	75 x 457	K120	0/180	5902062211125
63H624	75 x 533	K40	0/180	5902062211132
63H626	75 x 533	K60	0/180	5902062211149
63H628	75 x 533	K80	0/180	5902062211156
63H630	75 x 533	K100	0/180	5902062211163
63H632	75 x 533	K120	0/180	5902062211170

VERTO

## ŚCIERNICA LISTKOWA

Flap wheel / Blatt-Schleifscheibe / Листовой шлифовальный круг / Круг шлифовальный листовый / Lamellas csiszoló / Disc de rectificat / Brusný kotouč listkový / Brusny lamelový tanier / Brus z lističi / Slifavimo lapeliai / Lokšņu slīpēšanas riņķis / Lamell-lihvketas / Ламелен диск / Lepezasta brusna ploča / Kolut za brušenje / Τροχός λείανσης με πτερύγια / Abanico lijador / Spazzola lamellare / Disco abrasivo de folhas / Meule abrasive à lamelles / Schuurblad

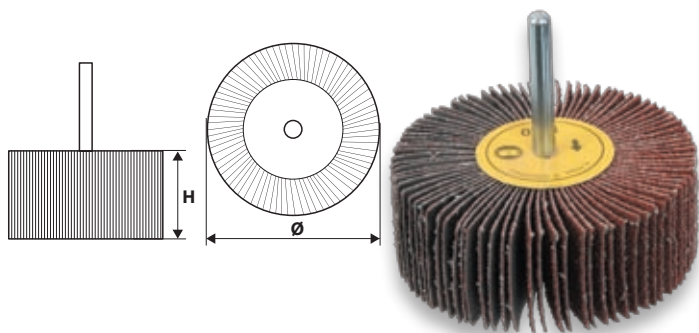

Ref.	Ø [mm]	H [mm]	gradacija	☒	EAN
63H702	40	20	K40	0/10	5902062211378
63H704	40	20	K60	0/10	5902062211385
63H706	40	20	K80	0/10	5902062211392
63H712	60	30	K40	0/10	5902062211408
63H714	60	30	K60	0/10	5902062211415
63H716	60	30	K80	0/10	5902062211422
63H722	80	30	K40	0/10	5902062211439
63H724	80	30	K60	0/10	5902062211446
63H726	80	30	K80	0/10	5902062211453



## KRAŹKI ŚCIERNE

Abrasive discs / Schleifscheibe / Шлифовальные круги / Круги шлифовальные / Csiszolákorongok / Discuri abrazive / Brusné kroužky / Brusne kotúče / Brusne plošče / Slifavimo diskeliai / Slīpēšanas aplī / Lihvrõngad / Абразивни дискове / Brusni kolutiči / Diskovi za brušenje / Δίσκοι λείανσης / Hoja de lija circular / Dischi abrasivi / Discos abrasivos / Roulette abrasive / Schuurwielen

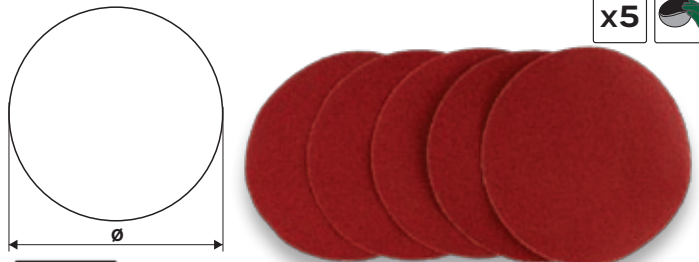

Ref.	Ø [mm]	gradacija	☒	EAN
63H104	125	K40	0/30	5902062202598
63H106	125	K60	0/30	5902062202604
63H108	125	K80	0/30	5902062202611
63H110	125	K100	0/30	5902062202628
63H112	125	K120	0/30	5902062202635



## KRAŹKI ŚCIERNE

Abrasive discs / Schleifscheibe / Шлифовальные круги / Круги шлифовальные / Csiszolákorongok / Discuri abrazive / Brusné kroužky / Brusne kotúče / Brusne plošče / Slifavimo diskeliai / Slīpēšanas aplī / Lihvrõngad / Абразивни дискове / Brusni kolutiči / Diskovi za brušenje / Δίσκοι λείανσης / Hoja de lija circular / Dischi abrasivi / Discos abrasivos / Roulette abrasive / Schuurwielen

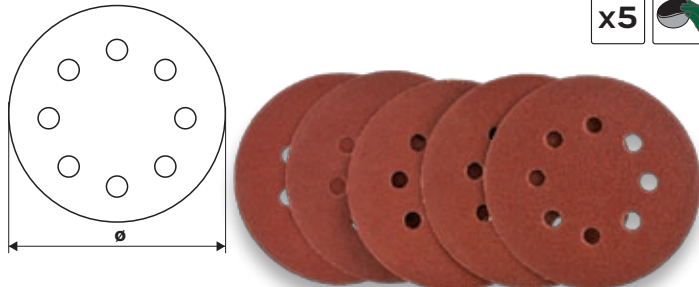

Ref.	Ø [mm]	gradacija	☒	EAN
63H204	125	K40	0/30	5902062202543
63H206	125	K60	0/30	5902062202550
63H208	125	K80	0/30	5902062202567
63H210	125	K100	0/30	5902062202574
63H212	125	K120	0/30	5902062202581



## PAPIERY ŚCIERNE

Abrasive papers / Schleifpapier / Наждачная бумага / Папір наждачний / Csiszoláppapírok / Hártili abrazive / Brusné papíry / Brusne papjere / Brusni papirji / Slifavimo papjeriai / Slīppapīrs / Lihvpaber / Абразивна хартия / Brusni papiri / Smirgl-papiri / Τυαλόχαρτο / Lijas / Carte abrasive / Folhas de lixa / Papiers abrasifs / Schuurpapieren

x5

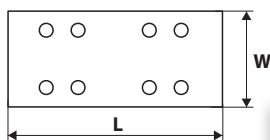

Ref.	W x L [mm]	gradacija	☒	EAN
63H504	93 x 230	K40	0/30	5902062210708
63H506	93 x 230	K60	0/30	5902062210715
63H508	93 x 230	K80	0/30	5902062210722
63H512	93 x 230	K120	0/30	5902062210746

## SZCZOTKA DRUCIANA

Wire brush / Drahtbürste / Щетка проволочная / Щітка по металу / Spidkefe / Perie metal / Drátěný kartáč / Keľa drôtená univerzálna / Žična krtača / Vielinis šepety / Drāšu birste / Traathari / Четка мелена / Cetka sa PVC drškom / Cetka / Συρμάτινη βούρτσα / Cepillo de alambre / Spazzola metallica / Escova de arame / Brosse métallique / Draadborstel

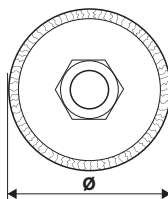
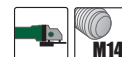

Ref.	Ø [mm]	☒	EAN
62H110	75	0/12	5902062070890
62H111	100	0/12	5902062070906

## SZCZOTKA DRUCIANA

Wire brush / Drahtbürste / Щетка проволочная / Щітка по металу / Spidkefe / Perie metal / Drátěný kartáč / Keľa drôtená univerzálna / Žična krtača / Vielinis šepety / Drāšu birste / Traathari / Четка мелена / Cetka sa PVC drškom / Cetka / Συρμάτινη βούρτσα / Cepillo de alambre / Spazzola metallica / Escova de arame / Brosse métallique / Draadborstel

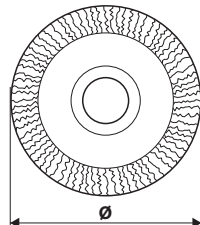
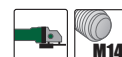

Ref.	Ø [mm]	☒	EAN
62H112	100	0/12	5902062070913
62H121	115	0/12	5902062070920

### SZCZOTKA DRUCIANA

Wire brush / Drahtbürste / Щетка проволочная / Щітка по металу / Spidkefe / Perie metal / Drátěný kartáč / Keľa drôtená univerzálna / Žična krtača / Vielinis šepetys / Drāšu birste / Traathari / Чемка телена / Cetka sa PVC drškom / Cetka / Συρμάτινη Βούρτσα / Cepillo de alambre / Spazzola metallica / Escova de arame / Brosse métallique / Draadborstel

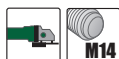
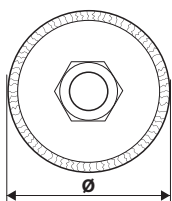

Ref.	Ø [mm]	☒	EAN
62H130	65	0/12	5902062070937
62H131	100	0/12	5902062070944

### SZCZOTKA DRUCIANA

Wire brush / Drahtbürste / Щетка проволочная / Щітка по металу / Spidkefe / Perie metal / Drátěný kartáč / Keľa drôtená univerzálna / Žična krtača / Vielinis šepetys / Drāšu birste / Traathari / Чемка телена / Cetka sa PVC drškom / Cetka / Συρμάτινη Βούρτσα / Cepillo de alambre / Spazzola metallica / Escova de arame / Brosse métallique / Draadborstel

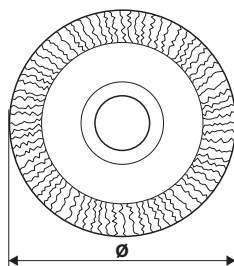

Ref.	Ø [mm]	☒	EAN
62H312	100	0/12	5902062071026
62H315	150	0/12	5902062071040

### SZCZOTKA DRUCIANA

Wire brush / Drahtbürste / Щетка проволочная / Щітка по металу / Spidkefe / Perie metal / Drátěný kartáč / Keľa drôtená univerzálna / Žična krtača / Vielinis šepetys / Drāšu birste / Traathari / Чемка телена / Cetka sa PVC drškom / Cetka / Συρμάτινη Βούρτσα / Cepillo de alambre / Spazzola metallica / Escova de arame / Brosse métallique / Draadborstel

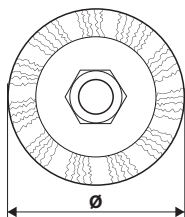

Ref.	Ø [mm]	☒	EAN
62H140	115	0/12	5902062070951
62H141	150	0/12	5902062070968

### SZCZOTKA DRUCIANA

Wire brush / Drahtbürste / Щетка проволочная / Щітка по металу / Spidkefe / Perie metal / Drátěný kartáč / Keľa drôtená univerzálna / Žična krtača / Vielinis šepetys / Drāšu birste / Traathari / Чемка телена / Cetka sa PVC drškom / Cetka / Συρμάτινη Βούρτσα / Cepillo de alambre / Spazzola metallica / Escova de arame / Brosse métallique / Draadborstel

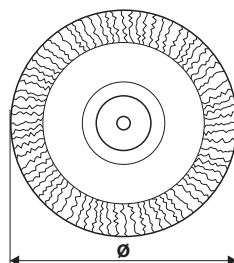

Ref.	Ø [mm]	☒	EAN
62H320	75	0/30	5902062071057
62H321	100	0/30	5902062071064

### SZCZOTKA DRUCIANA

Wire brush / Drahtbürste / Щетка проволочная / Щітка по металу / Spidkefe / Perie metal / Drátěný kartáč / Keľa drôtená univerzálna / Žična krtača / Vielinis šepetys / Drāšu birste / Traathari / Чемка телена / Cetka sa PVC drškom / Cetka / Συρμάτινη Βούρτσα / Cepillo de alambre / Spazzola metallica / Escova de arame / Brosse métallique / Draadborstel

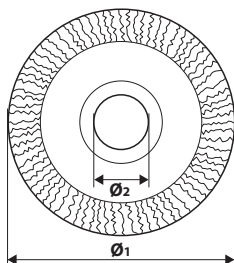

Ref.	Ø1 [mm]	Ø2 [mm]	redukcija [mm]	☒	EAN
62H210	125	20	16, 12	0/12	5902062070975
62H211	150	32	25, 22, 20, 16, 12	0/12	5902062070982
62H212	200	32	25, 22, 20, 16, 12	0/12	5902062070999

### SZCZOTKA DRUCIANA

Wire brush / Drahtbürste / Щетка проволочная / Щітка по металу / Spidkefe / Perie metal / Drátěný kartáč / Keľa drôtená univerzálna / Žična krtača / Vielinis šepetys / Drāšu birste / Traathari / Чемка телена / Cetka sa PVC drškom / Cetka / Συρμάτινη Βούρτσα / Cepillo de alambre / Spazzola metallica / Escova de arame / Brosse métallique / Draadborstel

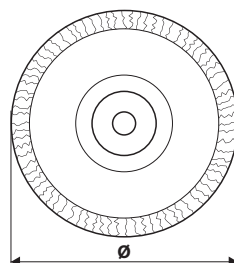

Ref.	Ø [mm]	☒	EAN
62H330	50	0/30	5902062071071
62H331	75	0/12	5902062071088

## SZCZOTKA DRUCIANA

Wire brush / Drahtbürste / Щетка проволочная / Щітка по металу / Spidkefe / Perie metal / Drátěný kartáč / Kefa drátěná univerzálna / Žična krtača / Vieliniai šepetys / Drážu birste / Traathari / Четка мелена / Četka sa PVC drškóm / Četka / Συρμάτινη βούρτσα / Cepillo de alambre / Spazzola metallica / Escova de arame / Brosse métallique / Draadborstel

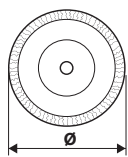

Ref.	Ø [mm]	⊠	EAN
62H341	24	0/36	5902062071101

## SZCZOTKA ŚCIERNA

Abrasive brush / Schleifbürste / Шлифовальная щётка / Щітка дратяна / Drótkefe / Perie abrazivă / Brusný kartáč / Brúsna kefka / Brusna ščetka / Ślijavimo šepetys / Blipešanas suka / Lihvimishari / Абразивна четка / Brusna četka / Abrazivna četka / Βούρτσα λείανσης / Cepillo lijador / Spazzola abrasiva / Escova abrasiva / Brosse abrasive / Schuurborstel

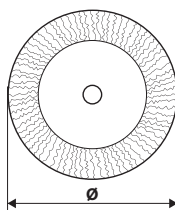

Ref.	Ø [mm]	⊠	EAN
62H712	75	12/120	5902062071699
62H714	100	12/120	5902062071705

## SZCZOTKI DRUCIANE

Wire brushes / Drahtbürsten / Щетки проволочные / Щітки дратяні / Drótkefék / Perie de sâmtă / Drátěné kartáče / Drátěné kefky / Žične ščetke / Vieliniai šepetys / Stieplu sukas / Terasharjad / Телену четки / Žičane četke / Žičane četke / Βούρτσες αμυγδαίνες / Cepillos de alambre / Spazzole in fili d'acciaio / Escovas de arame / Broses métalliques / Draadborstels



Ref.	Ø [mm]	⊠	EAN
62H613	x3	0/10	5902062070883
62H614	x5	0/10	5902062070067

## SZCZOTKA ŚCIERNA

Abrasive brush / Schleifbürste / Шлифовальная щётка / Щітка дратяна / Drótkefe / Perie abrazivă / Brusný kartáč / Brúsna kefka / Brusna ščetka / Ślijavimo šepetys / Blipešanas suka / Lihvimishari / Абразивна четка / Brusna četka / Abrazivna četka / Βούρτσα λείανσης / Cepillo lijador / Spazzola abrasiva / Escova abrasiva / Brosse abrasive / Schuurborstel

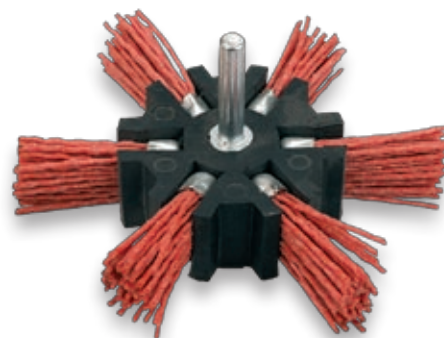
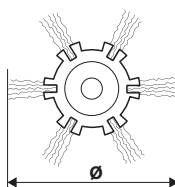

Ref.	Ø [mm]	⊠	EAN
62H720	100	12/120	5902062071736

## SZCZOTKA ŚCIERNA

Abrasive brush / Schleifbürste / Шлифовальная щётка / Щітка дратяна / Drótkefe / Perie abrazivă / Brusný kartáč / Brúsna kefka / Brusna ščetka / Ślijavimo šepetys / Blipešanas suka / Lihvimishari / Абразивна четка / Brusna četka / Abrazivna četka / Βούρτσα λείανσης / Cepillo lijador / Spazzola abrasiva / Escova abrasiva / Brosse abrasive / Schuurborstel

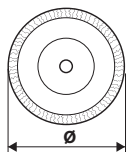

Ref.	Ø [mm]	⊠	EAN
62H708	65	12/120	5902062071675
62H710	75	12/120	5902062071682

## BRZESZCZOTY DO WYRZYNARKI

Jigsaw blades / Sägeblätter für Schweißsäge / Полотна для лобзика / Полотно пильне до лобзика / Fűrészlapok szűrőfűrészhez / Pânze de ferăstrău de decupat / Pílové listy pro listovou pilu / Listy do priamočiarej píly / Listi za vboodno žago / Pjüklükai siaurapjükliai / finierzäga asmeni / Tikksae terad / Листове за ажурна дървообработваща машина / Listovi pile za ubodnu pilu / Sečiva za ručnu testeru / Приονόλαμες σέγας / Hojas para sierra de calar / Lame per seghetto alternativo / Lâminas p. Máquina de entalhar / Lames de scie pour scie sauteuse / Mesbladen voor decoupeerzaag

x5



Ref.	TYP	⊠	EAN
64H105	U	0/500	5902062635150
64H205	T	0/500	5902062636157

## BRZESZCZOTY DO WYRZYNARKI

Jigsaw blades / Sägeblätter für Schweißsäge / Полотно для лобзика / Полотно пильне до лобзика / Fűrészlapok szűrőfűrészhez / Pánze de ferástráu de decupat / Pilové listy pro listovou pilu / Listy do priamočiarej pilky / Listi za vbohno žago / Pjüklükai siaurapjüklüi / Finierzága asmeņi / Tikksae terad / Листове за ажурна дървообработваща машина / Listovi pile za ubodnu pilu / Sečiva za ručnu testeru / Προιονόλαμες σέγας / Hojas para sierra de calar / Lame per seghetto alternativo / Lâminas p. Máquina de entalhar / Lames de scie pour scie sauteuse / Mesbladen voor decoupeerzaag

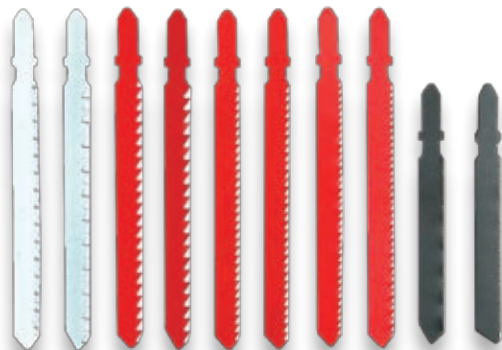

x10

Ref.	TYP	☒	EAN
64H110	U	0/25	5902062635105
64H210	T	0/25	5902062636102

## BRZESZCZOTY DO WYRZYNARKI

Jigsaw blades / Sägeblätter für Schweißsäge / Полотно для лобзика / Полотно пильне до лобзика / Fűrészlapok szűrőfűrészhez / Pánze de ferástráu de decupat / Pilové listy pro listovou pilu / Listy do priamočiarej pilky / Listi za vbohno žago / Pjüklükai siaurapjüklüi / Finierzága asmeņi / Tikksae terad / Листове за ажурна дървообработваща машина / Listovi pile za ubodnu pilu / Sečiva za ručnu testeru / Προιονόλαμες σέγας / Hojas para sierra de calar / Lame per seghetto alternativo / Lâminas p. Máquina de entalhar / Lames de scie pour scie sauteuse / Mesbladen voor decoupeerzaag

x10



Ref.	TPI	☒	EAN
64H915	15	0/1	5902062649157

## AKCESORIA DO MINIWIERTARKI

Minidrill accessories / Zubehör für Minibohrmachine / Аксессуары для мини-дрели / Принадлежности до мини-дрели / Tartozékok minifűrőgéphez / Accesorii pentru minibormășină / Příslušenství pro minivrtáčku / Príslušenstvo k minivrtáčke / Pribor za minivrtalnik / Mini sukutvo priedai / Miniurbjmašinas piederumi / Minikruvikeeraja tarvikud / Аксесоари за минипробивна машина / Pribor za minibušilicu / Pribor za mini bušilicu / Αξεσουάρ για μικροβόρνο / Accesorios para mini taladro / Accessori per minitrapano / Acessórios para mini berbequim / Accessoires pour mini perceuse / Accessoires voor mini-boormachine

x100



Ref.	☒	EAN
50G029	0/6	5902062500298

## UCHWYT STOŁOWY DO WIERTARKI

Drilling machine holder / Tischaufnahme für Bohrmaschine / Держатель для дрели с тисками для крепления к столу / Затиск верстатный для дрели / Fűrőgép asztali állvány / Suport pentru masina de gaurit / Stolní držák pro vrtáčku / Stolové upínadlo na vrtáčku / Mizno držalo za vrtalnik / Staliniai sprauštuvai, gręztuvui / Urbjmašinas galda turētājs / Lauakinnitus trellile / Настолен държач за пробивна машина / Stolna hvataljka za bušilicu / Stoli držač za bušilicu / Ορθοστάτης βραχάου με σφυκτάρα / Soporte de sujeción para taladradora / Supporto con morsetto per trapano / Supporto con morsetto per trapano / Suporte de mesa p. Berbequim / Monture d'établi pour perceuse / Tafelhouder voor boormachine

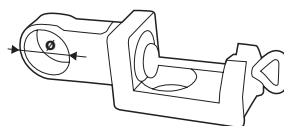

Ref.	Ø [mm]	☒	EAN
65H115	43	0/10	5902062295088

## STATYW DO WIERTARKI

Drill stand / Gestell für Bohrmaschine / Держатель для дрели / Штатив до дрели / Fűrőállvány / Stativ pentru masina de gaurit / Stojan na vrtáčku / Stojan na vrtáčku / Stojalo za vrtalnik / Stovas gręztuvui / Urbjmašinas stativs / Stativi trellile / Στατiς за пробивна машина / Stativ za bušilicu / Stativ za bušilicu / Ορθοστάτης βραχάου / Soporte para taladradoras / Supporto per trapano / Suporte de berbequim / Bâti pour perceuse / Steun voor boormachine



Ref.	H [mm]	Ø [mm]	Ra [mm]	☒	EAN
65H105	400	43	60	0/10	5902062160737

VERTO



**STATYW DO SZLIFIEREK KĄTOWYCH**

Angle grinder support / Gestell für Winkelschleifer / Держатель для угловых шлифмашин / Штатив до шлифмашини кутова (болгарки) / Állvány sarokcsiszolóhoz / Stativ pentru polizor unghiular / Stojan na uhlové brusky / Stojan na uhlove brusky / Stojalo za kotni brusilnik / Stovas kampiniam šlifjuokliui / Leņķa slīpmašīnas statīvs / Statīvs nurklīhvijale / Статив за ъглошлайф / Stativ za kutne brusilice / Stativ za ugaone brusilice / Орθωστάτης για γωνιακού λειαντήρα / Suporte para amoladora angular / Supporto per smerigliatrice angolare / Suporte para esmerilhadora de canto / Bâti pour meuleuses d'angle / Steun voor verstekschuurmachines



Ref.	Ø [mm]	☒	EAN
65H110	115, 125	0/10	5902062295071

**UCHWYT WIERTARSKI**

Drill chuck / Bohrfutter / Патрон для дрели / Патрон до дрелию / Fúrótokmány / Mandrină de găurit / Skličidlo pro vrtáky / Slučidlo / Vrtalna glava / Griebtuvas grežtuvui / Urbjmašinas patrona / Drelli padrun / Патрон за бормашина / Stezna glava-borfuter / Stezna glava-borfuter / Κεντροσφικτική δράπανου / Portabrocas / Manubrio di trapano per chiave / Suporte de berbequim / Mandrin de perçage / Boorhouder



Ref.	Ø	Ra [mm]	☒	EAN
66H108	3/8" x 24	1,0 - 10,0	0/50	5902062160386
66H112	1/2" x 20	1,0 - 13,0	0/40	5902062163127

**UCHWYT WIERTARSKI**

Drill chuck / Bohrfutter / Патрон для дрели / Патрон до дрелию / Fúrótokmány / Mandrină de găurit / Skličidlo pro vrtáky / Slučidlo / Vrtalna glava / Griebtuvas grežtuvui / Urbjmašinas patrona / Drelli padrun / Патрон за бормашина / Stezna glava-borfuter / Stezna glava-borfuter / Κεντροσφικτική δράπανου / Portabrocas / Manubrio di trapano per chiave / Suporte de berbequim / Mandrin de perçage / Boorhouder



Ref.	Ø	Ra [mm]	☒	EAN
66H208	3/8" x 24	1,0 - 10,0	0/50	5902062170385
66H212	1/2" x 20	1,0 - 13,0	0/40	5902062173126

**ADAPTER DO UCHWYTU WIERTARSKIEGO**

Drill chuck adaptor / Adapter f. Bohrfutter / Переходник для патрона к дрели / Адаптер до патрону дрели / Adapter fúrókalapácsoló / Adaptor p/u mandrina de stringere a sfredelului / Adapter sklčidla na vrtáky / Adapter na sklčidlo SDS / Adapter za vrtalnik / Adapteris grežtuvu griebtuvui / Adaptors urbjmašinas patronai / Drellipadruni adapter / SDS Adaptor / SDS adapter za borfuter / Adapter za busilicu / Ανάπτορας τσok δράπανου / Adaptador para mandril / Adattatore per presa da trapano / Adaptador de Suporte de berbequim / Adaptateur de mandrin de perceuse / Adaptor voor boorhandvat



Ref.	gwint	☒	EAN
60H245	1/2" x 20	0/500	5902062602459

**KLUCZ DO UCHWYTU WIERTARSKIEGO**

Drill chuck key / Bohrfutterschlüssel / Ключ для патрона к дрели / Ключ для патрону до дрели / Tokmánykulcs / Cheie sfredelie a mandrinei / Klíč ke sklčidlu pro vrtáky / Klíč do sklčidla / Ključ za vrtalno glavo / Grežtuvu griebtuvu raktas / Urbjmašinas patronas atslėga / Drelli padruni vōti / Ключ за патрон / Ključ za borfuter / Ključ za borfuter / Кλειδί για κεντροσφικτική δράπανου / Llave para mandril / Chiave per manubrio di trapano / Chave p. suporte de berbequim / Clef de mandrin de perceuse / Boorhandvatsleutel



Ref.	Ra [mm]	☒	EAN
66H310	10	0/200	5902062663108
66H313	13	0/200	5902062663139

**KLUCZ DO SZLIFIERKI KĄTOWEJ**

Angle grinder key / Schlüssel für Winkelschleifer / Ключ для углового шлифовального станка / Ключ до шлифмашинки кутова (болгарки) / Kulcs sarokcsiszolóhoz / Cheie pentru polizor unghiular / Klíč pro uhlovou brusku / Klíč do uhlovej brusky / Ključ za kotni brusilnik / Raktas kampiniam šlifjuokliui / Leņķu slīpmašīnas atslėga / Nurklīhvija vōti / Ключ за ъглошлайф / Ključ za kutnu brusilicu / Ključ za ugaonu brusilicu / Кλειδί γωνιακού λειαντήρα / Llave para amoladora angular / Chiave universale per rettificatrice angolare / Chave universal p. disco de limar de canto / Clef universelle à meuleuse d'angle / Sleutel voor verstekschuurmachine



Ref.	☒	EAN
66H320	12/72	5902062663207